

# DISPENSING EQUIPMENT

METAL NEEDLES, PLASTIC NEEDLES, TT NEEDLES, PP  
NEEDLES HIGH-PRECISION NEEDLES  
EXTERNALLY THREADED NEEDLES, ETC

# DIRECTOR Y CONTENT S

Plastic steel thread needle	03
UV Black threaded needle	05
Plastic steel thread chamfer needle	06
Plastic steel bayonet needle	07
Plastic steel 45° bending needle head	09
PP needle	11
PP integrated needle	13
Plastic steel /pp lengthening needle	15
TT Needle	17
All plastic TT bent needle	21
All plastic dental curved needle	23
Metal needle	25
Metal curved needle head	27
Metal multi-tube needle	29
Plastic steel double tube needle head	30
Brush Needle	31
Teflon needle	35
Aluminum inlaid needle	37
Sheath tip needle	39
Animal needle	41
Metal external thread needle	43
Metal double threaded needle head	45
Side hole needle head	47
Extended and thickened needle head	49
High precision needle	51
High precision integrated bayonet needle	53
High precision integrated threaded needle head	55
Winnison split needle	57
Hexagonal base soldering needle	59
Stainless steel gastric lavage needle	60
Metal internal thread solder needle	61
Special base needle	63
Bi-directional stainless steel needle	64
Tubular coaxial needle head	65
Musashi Metal Needle	67
Plastic flat needle for dispensing valve	68
Blunt needle	69
Bidirectional injection chromatographic needle	71

# DISPENSING NEEDLE MULTIPLE SPECIFICATIONS



01

02

# Plastic steel thread needle

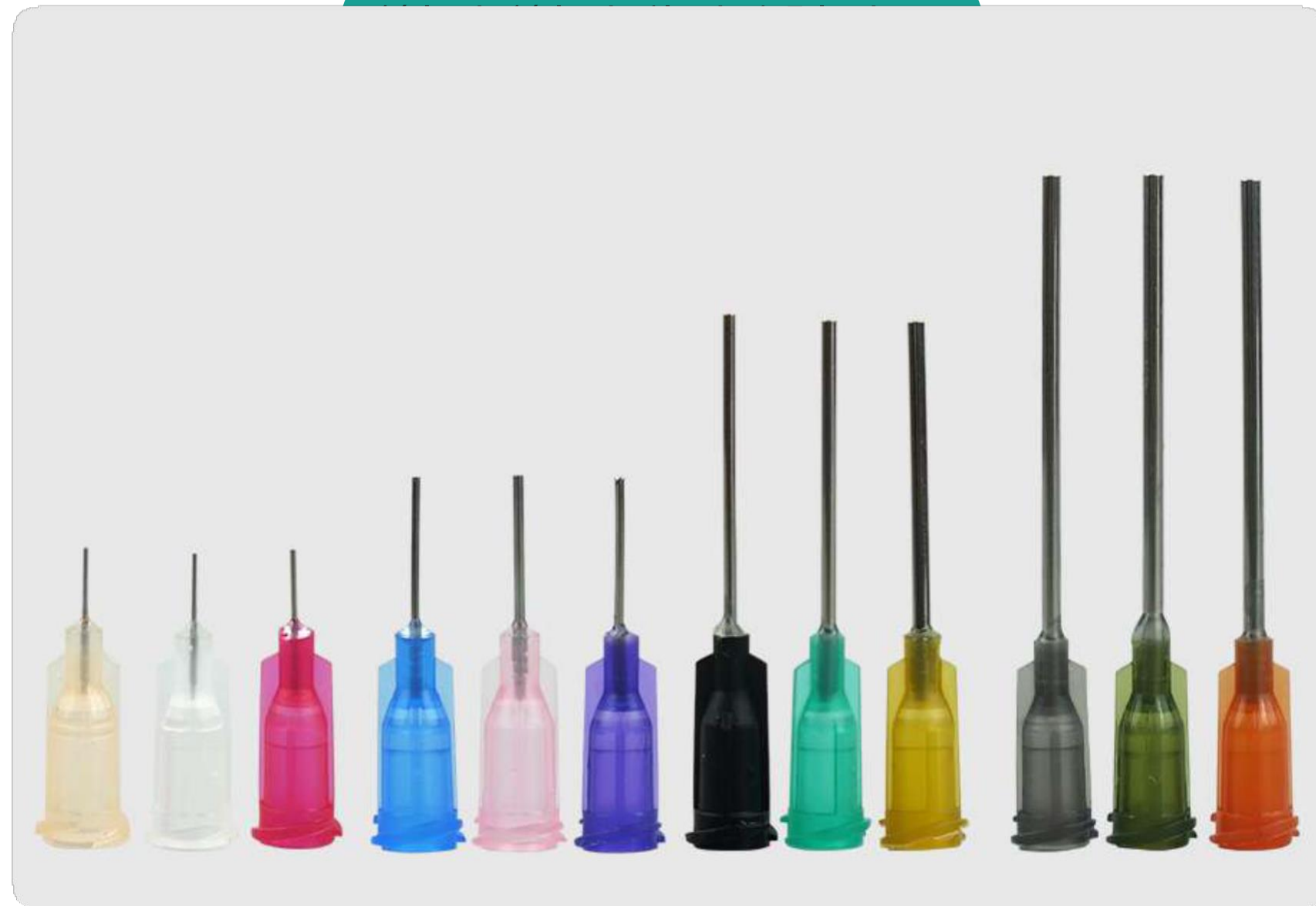

## Plastic steel threaded needle head

Model number	Inside diameter	Outside diameter	Wall thickness	Exposed length				Custom
				¼ inches	½ inches	1 inch	1.5 inches	
8G	3.5mm	4mm	0.25mm	6.5mm	13mm	25.4mm	38mm	support
10G	2.85mm	3.45mm	0.3mm	6.5mm	13mm	25.4mm	38mm	support
11G	2.45mm	2.95mm	0.25mm	6.5mm	13mm	25.4mm	38mm	support
12G	2.3mm	2.8mm	0.25mm	6.5mm	13mm	25.4mm	38mm	support
13G	1.9mm	2.4mm	0.25mm	6.5mm	13mm	25.4mm	38mm	support
14G	1.55mm	2.08mm	0.25mm	6.5mm	13mm	25.4mm	38mm	support
15G	1.3mm	1.78mm	0.25mm	6.5mm	13mm	25.4mm	38mm	support
16G	1.15mm	1.6mm	0.2mm	6.5mm	13mm	25.4mm	38mm	support
17G	1.05mm	1.5mm	0.2mm	6.5mm	13mm	25.4mm	38mm	support
18G	0.86mm	1.26mm	0.2mm	6.5mm	13mm	25.4mm	38mm	support
19G	0.72mm	1.02mm	0.15mm	6.5mm	13mm	25.4mm	38mm	support

Model number	Inside diameter	Outside diameter	Wall thickness	Exposed length				Custom
				¼ inch	½ inch	1 inch	1.5 inches	
20G	0.6mm	0.9mm	0.15mm	6.5mm	13mm	25.4mm	38mm	support
21G	0.5mm	0.8mm	0.15mm	6.5mm	13mm	25.4mm	38mm	support
22G	0.4mm	0.7mm	0.15mm	6.5mm	13mm	25.4mm	38mm	support
23G	0.3mm	0.6mm	0.15mm	6.5mm	13mm	25.4mm	38mm	support
24G	0.27mm	0.55mm	0.15mm	6.5mm	13mm	25.4mm	38mm	support
25G	0.25mm	0.5mm	0.125mm	6.5mm	13mm	25.4mm	38mm	support
26G	0.22mm	0.45mm	0.125mm	6.5mm	13mm	25.4mm	38mm	support
27G	0.2mm	0.4mm	0.125mm	6.5mm	13mm	25.4mm	38mm	support
28G	0.17mm	0.32mm	0.075mm	6.5mm	13mm	25.4mm	38mm	support
30G	0.15mm	0.3mm	0.075mm	6.5mm	13mm	25.4mm	38mm	support
32G	0.1mm	0.24mm	0.08mm	6.5mm	13mm	25.4mm	38mm	support
34G	0.06mm	0.23mm	0.08mm	6.5mm	13mm	25.4mm	38mm	support

Note: The above data may have slight errors due to manual measurement

## Product characteristics

High-precision stainless steel pipe, after advanced processing for internal and external precision polishing, and then after more than 3 times of ultrasonic fine washing, can completely eliminate the burr phenomenon, and let the needle inside completely clean, never pollute the glue. The insertion part of the needle uses an advanced penetration process, coupled with the selection of high-strength UV glue, to ensure that the connection part of the needle will not fall off.

The large flat rotating design, coupled with the precise fit of the needle barrel, makes the dispensing process easy and fast, and can guarantee absolute safety at 12 kg pressure.

The special base material blocks UV rays, ensuring that expensive UV glue is not wasted inside the needle during production.

# UV black threaded needle

¼ Inches ½ Inch UV Needle



## UV black threaded needle

Model number	Inside diameter	Outside diameter	Wall thickness	Exposed length		Custom
				¼ inch	½ inch	
25G	0.26mm	0.52mm	0.125mm	6.5mm	13mm	support
26G	0.25mm	0.46mm	0.125mm	6.5mm	13mm	support
27G	0.21mm	0.42mm	0.125mm	6.5mm	13mm	support
30G	0.16mm	0.31mm	0.075mm	6.5mm	13mm	support
32G	0.11mm	0.23mm	0.08mm	6.5mm	13mm	support

Note: The above data may have slight errors due to manual measurement

### Product characteristics

Plastic steel threaded needle head, made of stainless steel material, with a sturdy and durable base plastic material, commonly used in industrial dispensing, teaching experiments, etc. All steel pipe needles adopt a burr free processing process, with high liquid dispensing accuracy and no wire drawing. The needle seat adopts double spiral locking and large area rotation design, which only makes cooperation safer and disassembly easier. The needle can be used with a dispensing valve needle

tube adapter, and this needle base is black, which can prevent light. It is suitable for UV glue, shadowless glue, and other glue that needs to be protected from light.

# Plastic steel thread chamfer needle

¼ Inch ½ Inch chamfered needle



## Plastic steel thread chamfer needle

Model number	Inside diameter	Outside diameter	Wall thickness	Exposed length		Custom
				¼ Inch	½ Inch	
22G	0.42mm	0.72mm	0.15mm	6.5mm	13mm	support
23G	0.34mm	0.64mm	0.15mm	6.5mm	13mm	support
25G	0.26mm	0.52mm	0.125mm	6.5mm	13mm	support
27G	0.21mm	0.42mm	0.125mm	6.5mm	13mm	support
30G	0.16mm	0.31mm	0.075mm	6.5mm	13mm	support

Note: The above data may have slight errors due to manual measurement

### Product characteristics

Plastic steel screw chamfer needle, needle stainless steel, base plastic material is durable, often used in industrial dispensing, teaching experiments, etc., all steel pipe needles are using no burr processing technology, liquid discharge precision is high, no wire drawing, needle holder adopts double helix locking and large area rotation design, only make the coordination safer, and disassembly easier. The front end of the needle 2-3MM will be polished and made into a cone shape, which can apply to the fine gluing requirements of narrow and small parts.

# Plastic steel bayonet needle



## Product characteristics

Plastic steel bayonet needle, needle stainless steel, base plastic material is durable, often used in industrial dispensing, teaching experiments, etc., all steel pipe needles are using no burr processing technology, liquid discharge accuracy is high, no wire drawing, needle holder using bayonet design, only make the cooperation more safe, and easier to disassemble, plastic steel extension needle is divided into flat mouth pointed needle, The pointed needle has bulk and independent packaging, the thickness has 4.5-20 optional, the length has a variety of, if not can also support custom.

## Plastic steel bayonet needle

Model number	Inside diameter	Outside diameter	Wall thickness	Exposed length				Custom
				¼ Inch	½ Inch	1Inch	1.5 Inches	
16G	1.15mm	1.60mm	0.20mm	6.5mm	13mm	25.4mm	38mm	support
18G	0.84mm	1.26mm	0.20mm	6.5mm	13mm	25.4mm	38mm	support
19G	0.70mm	1.04mm	0.15mm	6.5mm	13mm	25.4mm	38mm	support
20G	0.60mm	0.90mm	0.15mm	6.5mm	13mm	25.4mm	38mm	support
21G	0.50mm	0.80mm	0.15mm	6.5mm	13mm	25.4mm	38mm	support
22G	0.40mm	0.70mm	0.15mm	6.5mm	13mm	25.4mm	38mm	support
23G	0.30mm	0.60mm	0.15mm	6.5mm	13mm	25.4mm	38mm	support
24G	0.28mm	0.55mm	0.15mm	6.5mm	13mm	25.4mm	38mm	support
25G	0.25mm	0.50mm	0.125mm	6.5mm	13mm	25.4mm	38mm	support
26G	0.23mm	0.45mm	0.125mm	6.5mm	13mm	25.4mm	38mm	support
27G	0.20mm	0.40mm	0.125mm	6.5mm	13mm	25.4mm	38mm	support

Note: The above data may have slight errors due to manual measurement

# Plastic steel 45 ° bending needle head



## Plastic steel threaded curved needle head

Model number	Inside diameter	Outside diameter	Wall thickness	Exposed length			Custom
				¼ Inch	1Inch	1.5 Inches	
8G	3.5mm	4mm	0.25mm	13mm	25.4mm	38mm	support
10G	2.85mm	3.45mm	0.3mm	13mm	25.4mm	38mm	support
11G	2.45mm	2.95mm	0.25mm	13mm	25.4mm	38mm	support
12G	2.3mm	2.8mm	0.25mm	13mm	25.4mm	38mm	support
13G	1.9mm	2.4mm	0.25mm	13mm	25.4mm	38mm	support
14G	1.55mm	2.08mm	0.25mm	13mm	25.4mm	38mm	support
15G	1.3mm	1.78mm	0.25mm	13mm	25.4mm	38mm	support
16G	1.15mm	1.6mm	0.2mm	13mm	25.4mm	38mm	support
17G	1.05mm	1.5mm	0.2mm	13mm	25.4mm	38mm	support
18G	0.86mm	1.26mm	0.2mm	13mm	25.4mm	38mm	support
19G	0.72mm	1.02mm	0.15mm	13mm	25.4mm	38mm	support

Model number	Inside diameter	Outside diameter	Wall thickness	Exposed length			Custom
				½ Inch	1Inch	1.5 Inches	
20G	0.6mm	0.9mm	0.15mm	13mm	25.4mm	38mm	support
21G	0.5mm	0.8mm	0.15mm	13mm	25.4mm	38mm	support
22G	0.4mm	0.7mm	0.15mm	13mm	25.4mm	38mm	support
23G	0.3mm	0.6mm	0.15mm	13mm	25.4mm	38mm	support
24G	0.27mm	0.55mm	0.15mm	13mm	25.4mm	38mm	support
25G	0.25mm	0.5mm	0.125mm	13mm	25.4mm	38mm	support
26G	0.22mm	0.45mm	0.125mm	13mm	25.4mm	38mm	support
27G	0.2mm	0.4mm	0.125mm	13mm	25.4mm	38mm	support
28G	0.17mm	0.32mm	0.075mm	13mm	25.4mm	38mm	support
30G	0.15mm	0.3mm	0.075mm	13mm	25.4mm	38mm	support
32G	0.1mm	0.24mm	0.08mm	13mm	25.4mm	38mm	support
34G	0.06mm	0.23mm	0.08mm	13mm	25.4mm	38mm	support

Note: The above data may have slight errors due to manual measurement

## Product characteristics

High precision stainless steel pipes, after advanced processing for precise internal and external polishing, and after more than 3 times of ultrasonic fine washing, can completely eliminate burrs and ensure complete cleanliness of the needle inside, without polluting the glue. The insertion part of the needle tube uses advanced penetration technology, combined with the use of high-strength UV adhesive, to ensure that the connecting part of the needle tube never falls off.

The large flat rotating design, coupled with precise coordination with the needle barrel, makes the dispensing process easy and fast, ensuring absolute safety under a pressure of 12 kilograms.

The special base material can block ultraviolet rays, ensuring that expensive UV glue is not wasted in the needle during the production process.

## About Customization

The plastic steel bayonet also supports customized bending needle heads, and the bending length, thickness, and thickness of the product can be customized.

# PP needle

## PP flexible needle



Model number	Inside diameter	Outside diameter	Colour	Exposed length				Custom
				¼ Inch	½ Inch	1Inch	1.5 Inches	
14G	1.3mm	1.7mm	olive	6.5mm	13mm	25.4mm	38mm	support
15G	1.15mm	1.7mm	amber	6.5mm	13mm	25.4mm	38mm	support
16G	1.02mm	1.5mm	grey	6.5mm	13mm	25.4mm	38mm	support
18G	0.8mm	1.2mm	green	6.5mm	13mm	25.4mm	38mm	support
20G	0.58mm	0.85mm	Pink	6.5mm	13mm	25.4mm	38mm	support
21G	0.5mm	0.75mm	purple	6.5mm	13mm	25.4mm	38mm	support
22G	0.4mm	0.7mm	blue	6.5mm	13mm	25.4mm	38mm	support
23G	0.3mm	0.55mm	yellow	6.5mm	13mm	25.4mm	38mm	support
25G	0.25-0.3mm	0.76mm	red	6.5mm	13mm	25.4mm	38mm	support

Note: The above data may have slight errors due to manual measurement

## Product characteristics

PP needles support customization of different models and lengths, with corrosion resistance and long service life. The needle tube has good flexibility and is easy to penetrate into complex working surfaces, and can also prevent scratching the surface of the product. Especially for some instant adhesive effects.



# PP integrated needle

PP integrated needle

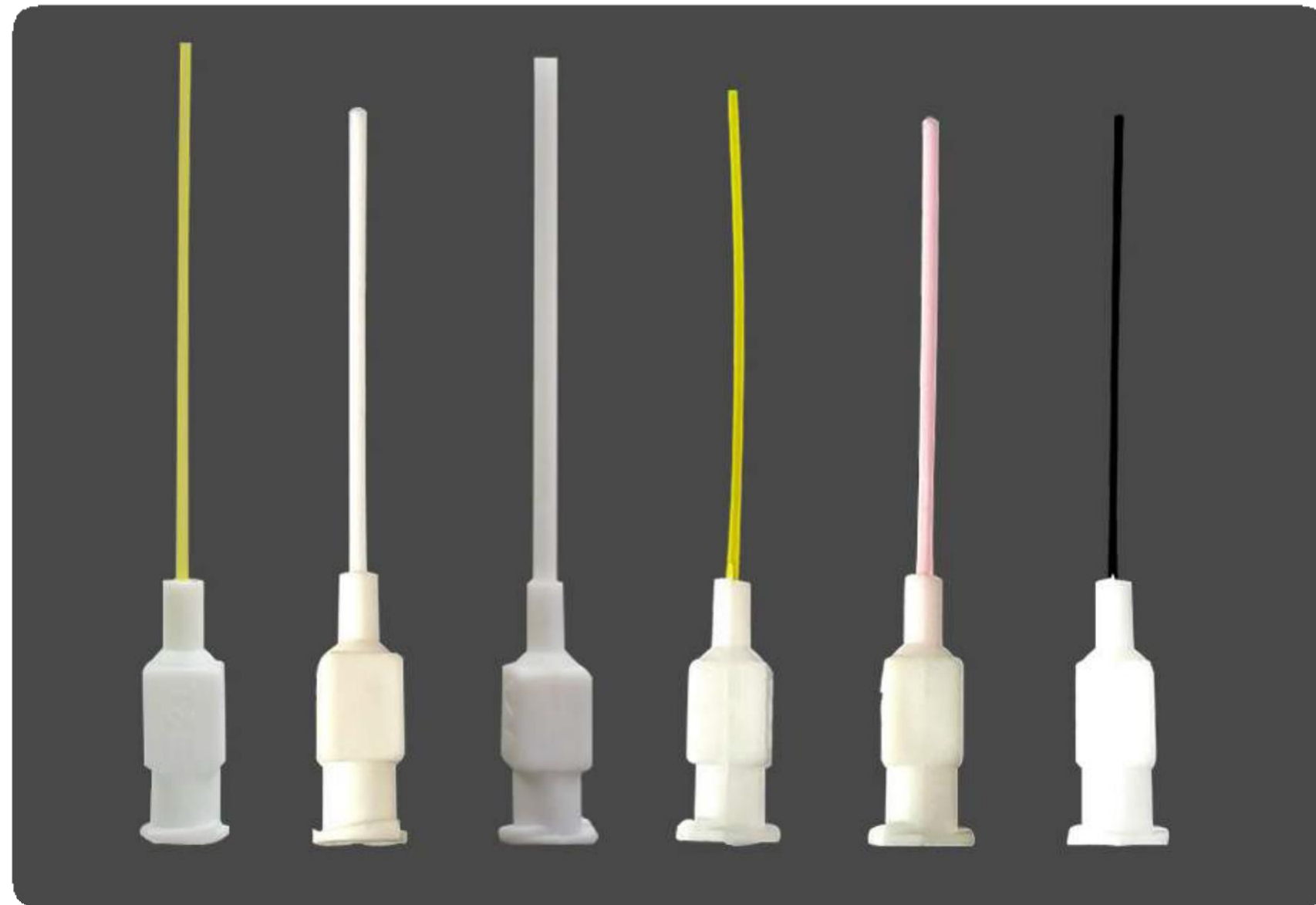

Model number	Inside diameter	Outside diameter	Exposed length	Total length	Custom
18G 1.5 inches	0.84mm	1.25mm	37.8mm	57mm	support
18G 1.5 inches	0.84mm	1.25mm	37.8mm	57mm	support
18G 0.5 inches	0.84mm	1.25mm	12.7mm	32mm	support
19G 1.5 inches	0.72mm	1mm	38.2mm	57.5mm	support
20G 1.5 inches	0.6mm	0.85mm	37.7mm	57mm	support
20G 1.5 inches	0.6mm	0.85mm	38.7mm	58mm	support
20G 0.5 inches	0.6mm	0.85mm	12.7mm	32mm	support
22G 1.5 inches	0.42mm	0.75mm	37.7mm	57mm	support
22G 1.5 inches	0.42mm	0.75mm	38mm	57.3mm	support
25G 1.5 inches	0.26mm	0.78mm	35.9mm	55.2mm	support
27G 1.5 inches	0.21mm	0.72mm	37.9mm	57.7mm	support

## Product characteristics

PP needles support customization of different models and lengths, with corrosion resistance and long service life. The needle tube has good flexibility and is easy to penetrate into complex working surfaces, and can also prevent scratching the surface of the product. Especially for some instant adhesive effects.

# Plastic steel /PP lengthened needle

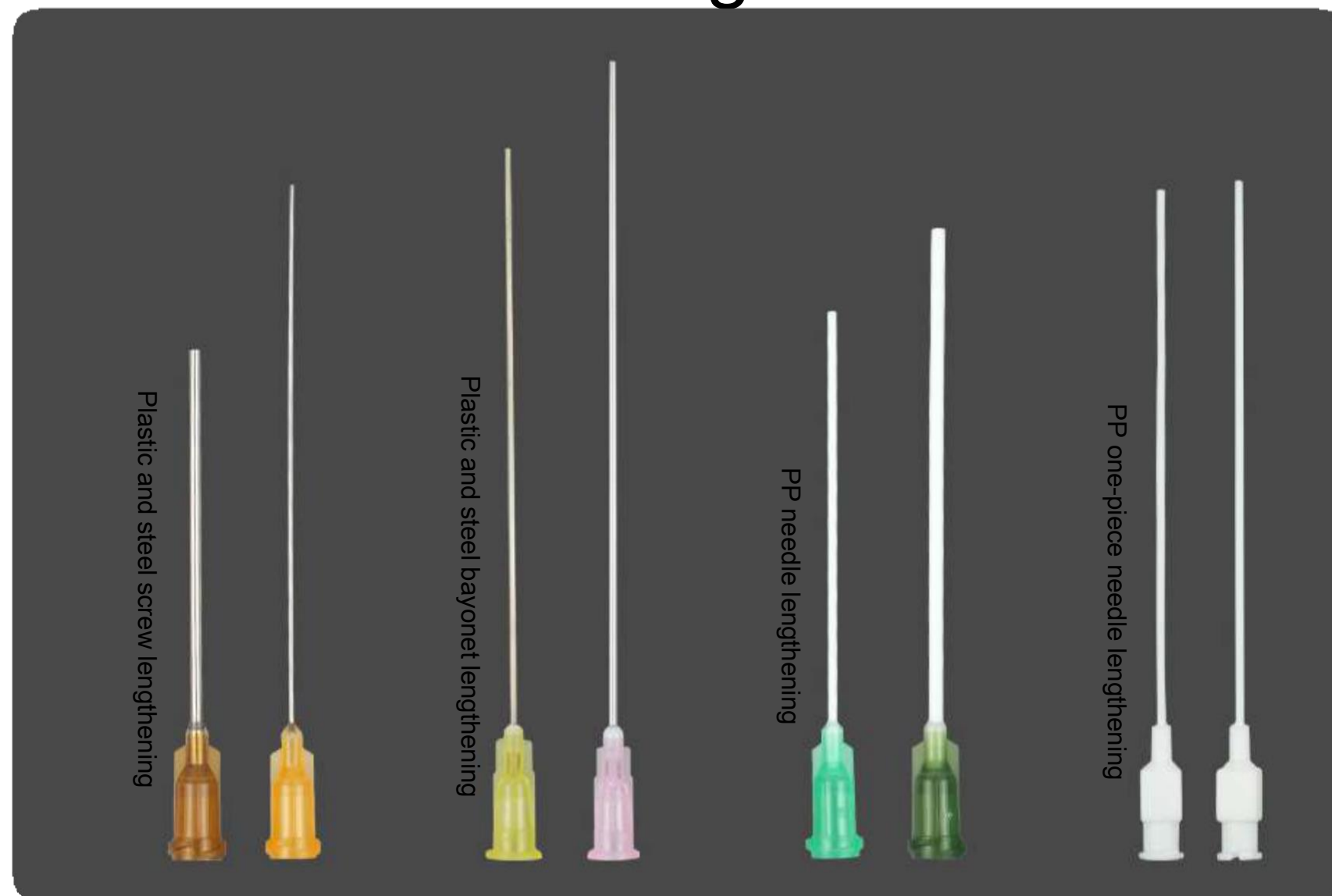

## Product characteristics

High-precision stainless steel pipe, after advanced processing for internal and external precision polishing, and then after more than 3 times of ultrasonic fine washing, can completely eliminate the burr phenomenon, and let the needle inside completely clean, never pollute the glue. The insertion part of the needle uses an advanced penetration process, coupled with the selection of high-strength UV glue, to ensure that the connection part of the needle will not fall off.

The large flat rotating design, coupled with the precise fit of the needle barrel, makes the dispensing process easy and fast, and can guarantee absolute safety at 12 kg pressure.

The special base material blocks UV rays, ensuring that expensive UV glue is not wasted inside the needle during production.

PP needle support to customize different types of different lengths, with corrosion resistance characteristics, long life. The flexibility of the needle part is good, easy to extend into the complex working face, and can also prevent scratching the product surface. Especially for some instant glue effect and good.

## Plastic steel /PP lengthened needle

Style	Model number	Exposed length	Base length	Wall thickness	Custom
Plastic and steel screw lengthening needle	8~32G	6.5~150mm	18mm	0.25~0.08mm	support
Plastic steel bayonet lengthened needle	8~32G	6.5~150mm	18mm	0.25~0.08mm	support
PP lengthened needle	8~32G	6.5~150mm	18mm	0.25~0.08mm	support
PP One-piece needle	8~32G	6.5~150mm	19mm	0.25~0.08mm	support

# TT needle

All plastic TT inclined needle



All plastic TT inclined needle

Model number	Colour	Inside diameter	Total length	Inner diameter of base	Outer diameter of base thread
10G	Light green	3mm	≈31.5mm	4.1mm	7.5mm
11G	Light orange	2.5mm	≈31.5mm	4.1mm	7.5mm
13G	Light blue	2mm	≈31.5mm	4.1mm	7.5mm
14G	Olive green	1.55mm	≈31.5mm	4.1mm	7.5mm
15G	Amber	1.35mm	≈31.5mm	4.1mm	7.5mm
16G	Light gray	1.20mm	≈31.5mm	4.1mm	7.5mm
18G	green	0.85mm	≈31.5mm	4.1mm	7.5mm
20G	Pink	0.6mm	≈31.5mm	4.1mm	7.5mm
21G	purple	0.5mm	≈31.5mm	4.1mm	7.5mm
22G	Blue/Black	0.4mm	≈31.5mm	4.1mm	7.5mm
23G	Orange	0.35mm	≈31.5mm	4.1mm	7.5mm

Note: The above data may have slight errors due to manual measurement

Model number	Colour	Inside diameter	Outside diameter	Inner diameter of base	Outer diameter of base thread
25G	Red	0.25mm	≈31.5	4.1mm	7.5mm
27G	Transparent/Black	0.2mm	≈31.5	4.1mm	7.5mm
30G	Pink/Transparent/Black	0.15mm	≈31.5	4.1mm	7.5mm
32G	black	0.06mm	≈31.5	4.1mm	7.5mm

Note: The above data may have slight errors due to manual measurement

## Product characteristics

1. Unique design, smooth flow, suitable for most fluids.
2. Glue with high consistency may cause blockages, poor flow, and other problems. T-shaped inclined needles can solve these problems.
3. The T-shaped needle head adopts a threaded interface and a cone-shaped needle tube design, which can ensure the smoothness of the adhesive. The YWS needle head material mouth is flat and without burrs, and is precision formed to ensure a smooth adhesive release.
4. The oblique needle provides a fast and smooth effect for fluids with high viscosity, especially for high viscosity or particle filling substances such as epoxy resin, PTV silicone resin, and brazing ointments.

## Yellow large TT needle



### Function:

Plastic dispensing needle (large) is used on the dispensing valve outlet, suitable for high viscosity adhesives such as silicone and yellow glue. The needle can be shortened according to the flow rate.

### Explanation:

The main material of the product is PP/polypropylene, non-toxic and odorless. The flow rate is stable, and the product is mainly used in the chemical industry. It can be used as a professional needle for experimental dispensing.

Model number	Inside diameter	Total length	Inner diameter of base	Outer diameter of base
No.1	0.55mm	50mm	5mm	6mm
No.2	0.5mm	48mm	4mm	6mm

## Blue large TT needle



### Features:

Plastic dispensing needle (large > for dispensing valve outlet, suitable for high viscosity glue, such as silicone, yellow glue, according to the flow size can cut the needle.

### Instructions:

The main material of the product is PP/ polypropylene, non-toxic, tasteless. Steady flow! Products are mainly used in chemical industry, can do experimen- tal dispensing professional needle.

Model number	Inside diameter	Total length	Inside diameter of base	Outer diameter of base
No.1	0.8mm	70mm	7.6mm	9mm
No.2	0.8mm	100mm	7mm	9mm

## TT needle with plug



1. Unique design, smooth flow, suitable for most fluids.

2. Glue with high consistency may cause blockages, poor flow, and other prob- lems. T-shaped inclined needles can solve these problems.

3. The T-shaped needle head adopts a bayonet interface and a cone-shaped needle tube design, which can ensure the smoothness of the adhesive. The YWS needle head material mouth is flat and without burrs, and is precision formed to ensure a smooth adhesive release.

Model number	Inside diameter	Total length	Inner diameter of base	Plug
TT-1	1.45mm	35.7mm	35.7mm	rotundity
TT-2	1.46mm	34.8mm	34.8mm	T-shaped



Note: The above data may have slight errors due to manual measurement

### Product characteristics

1. Unique design, smooth flow, suitable for most fluids.
2. TT needle with thread interface, cone-shaped needle design, can ensure the smooth glue, YWS needle mouth flat without burr, precision molding, to ensure the glue.
3. All plastic needles can also be made into elbows, Angle support customization. Needle can be used with dispensing valve, needle barrel and adapter.

### All plastic TT elbow needle

Model number	Colour	Inside diameter	Total length	Inner diameter of base	Outer diameter of base thread
10G	Light green	3mm	29mm	4.1mm	7.5mm
11G	Light orange	2.5mm	29mm	4.1mm	7.5mm
13G	Light blue	2mm	29mm	4.1mm	7.5mm
14G	Olive green	1.55mm	29mm	4.1mm	7.5mm
15G	Amber	1.35mm	29mm	4.1mm	7.5mm
16G	Light gray	1.20mm	29mm	4.1mm	7.5mm
18G	Green	0.85mm	29mm	4.1mm	7.5mm
20G	Pink	0.6mm	29mm	4.1mm	7.5mm
21G	Purple	0.5mm	29mm	4.1mm	7.5mm
22G	Blue	0.4mm	29mm	4.1mm	7.5mm
22G	Black	0.4mm	29mm	4.1mm	7.5mm
23G	Orange	0.35mm	29mm	4.1mm	7.5mm

Note: The above data may have slight errors due to manual measurement

# All plastic dental curved needles

Blue/transparent curved needle tip



## All plastic dental curved needle

Model number	Total length	Inside diameter	Outside diameter	Exposed length	Outer diameter of base thread
Dental Blue YK-1	30mm	0.25mm	0.54mm	20mm	7.4mm
Dental transparent YK-2	30mm	0.25mm	0.54mm	20mm	7.4mm

Note: The above data may have slight errors due to manual measurement

## Instructions for use

Used for root canal paste filling, MTA and other dental material delivery filling. Customizable

according to requirements.

# Metal Needle

¼ Inch ½ Inch 1Inch 1.5 Inches



## Product information

Product name: Metal needle

Product use: With dispensing valve/syringe/or adapter

Needle material: Copper nickel + stainless steel

Product packaging: Plastic + carton Specifications: 12 PCS /1 box

## Metal needle parameter

Model number	Inside diameter	Outside diameter	Wall thickness	Exposed length				Custom
				¼ Inch	½ Inch	1Inch	1.5 Inches	
8G	3.5mm	4mm	0.25mm	6.5mm	13mm	25.4mm	38mm	support
10G	2.85mm	3.45mm	0.3mm	6.5mm	13mm	25.4mm	38mm	support
11G	2.45mm	2.95mm	0.25mm	6.5mm	13mm	25.4mm	38mm	support
12G	2.3mm	2.8mm	0.25mm	6.5mm	13mm	25.4mm	38mm	support
13G	1.9mm	2.4mm	0.25mm	6.5mm	13mm	25.4mm	38mm	support
14G	1.55mm	2.08mm	0.25mm	6.5mm	13mm	25.4mm	38mm	support
15G	1.3mm	1.78mm	0.25mm	6.5mm	13mm	25.4mm	38mm	support
16G	1.15mm	1.6mm	0.2mm	6.5mm	13mm	25.4mm	38mm	support
17G	1.05mm	1.5mm	0.2mm	6.5mm	13mm	25.4mm	38mm	support

Note: The above data may have slight errors due to manual measurement

Model number	Inside diameter	Outside diameter	Wall thickness	Exposed length				Custom
				¼ Inch	½ Inch	1Inch	1.5 Inches	
18G	0.86mm	1.26mm	0.2mm	6.5mm	13mm	25.4mm	38mm	support
19G	0.72mm	1.02mm	0.15mm	6.5mm	13mm	25.4mm	38mm	support
20G	0.6mm	0.9mm	0.15mm	6.5mm	13mm	25.4mm	38mm	support
21G	0.5mm	0.8mm	0.15mm	6.5mm	13mm	25.4mm	38mm	support
22G	0.4mm	0.7mm	0.15mm	6.5mm	13mm	25.4mm	38mm	support
23G	0.3mm	0.6mm	0.15mm	6.5mm	13mm	25.4mm	38mm	support
24G	0.27mm	0.55mm	0.155mm	6.5mm	13mm	25.4mm	38mm	support
25G	0.25mm	0.5mm	0.125mm	6.5mm	13mm	25.4mm	38mm	support
26G	0.22mm	0.45mm	0.125mm	6.5mm	13mm	25.4mm	38mm	support
27G	0.2mm	0.4mm	0.125mm	6.5mm	13mm	25.4mm	38mm	support
28G	0.17mm	0.32mm	0.075mm	6.5mm	13mm	25.4mm	38mm	support
30G	0.15mm	0.3mm	0.075mm	6.5mm	13mm	25.4mm	38mm	support
32G	0.1mm	0.24mm	0.08mm	6.5mm	13mm	25.4mm	38mm	support

Note: The above data may have slight errors due to manual measurement

Note: The above data may have slight errors due to manual measurement

# Metal curved needle head

	Outside diameter	Wall thickness	Exposed length			Custom
			½ Inch	1Inch	1.5 Inches	
n	0.7					
n	0.6					
m	0.55					
m	0.5					
m	0.45					
n	0.4					
m	0.32					
m	0.3					
n	0.24					

## Product information

Product name: Metal bent needle  
 Needle material: Copper nickel + stainless steel  
 Product customization: Product length and curvature are supported by customization  
 Product packaging: Plastic + carton Specifications: 12 PCS /1 box

## Metal bending needle parameters

Model number	Inside diameter	Outside diameter	Wall thickness	Exposed length			Custom
				½ Inch	1Inch	1.5 Inches	
13G	1.9mm	2.4mm	0.25mm	13mm	25.4mm	38mm	support
14G	1.55mm	2.08mm	0.25mm	13mm	25.4mm	38mm	support
15G	1.3mm	1.78mm	0.25mm	13mm	25.4mm	38mm	support
16G	1.15mm	1.6mm	0.2mm	13mm	25.4mm	38mm	support
17G	1.05mm	1.5mm	0.2mm	13mm	25.4mm	38mm	support
18G	0.86mm	1.26mm	0.2mm	13mm	25.4mm	38mm	support
19G	0.72mm	1.02mm	0.15mm	13mm	25.4mm	38mm	support
20G	0.6mm	0.9mm	0.15mm	13mm	25.4mm	38mm	support
21G	0.5mm	0.8mm	0.15mm	13mm	25.4mm	38mm	support

Note: The above data may have slight errors due to manual measurement



# Metal multi-tube needle

Metal double/multiple/splay/extension needle

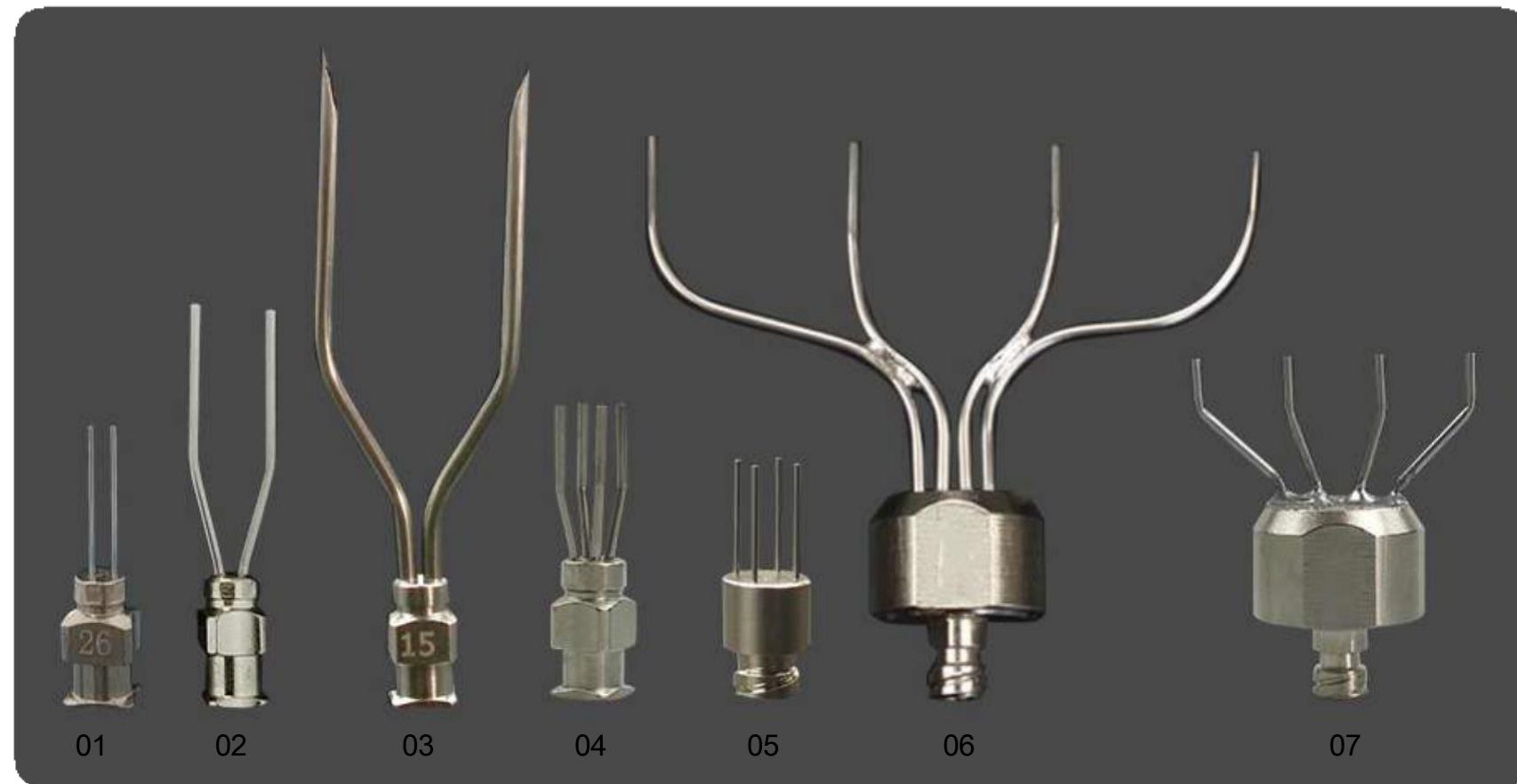

## Product information

Product name: Metal multi-tube needle

Product customization: The length and curvature of the product as well as the base are customized

Needle material: Copper nickel + stainless steel

## Metal multi-tube needle

Serial Number	Name	Available model	Exposed length			Custom
			½ Inch	1Inch	1.5 Inches	
01	Double tube needle	14G-28G	13mm	25.4mm	38mm	support
02	Eight shaped double tube needle head flat head	14G-28G	13mm	25.4mm	38mm	support
03	Eight shaped double tube pointed needle head	14G-28G	13mm	25.4mm	38mm	support
04	Four tubes metal needle	14G-28G	13mm	25.4mm	38mm	support
05	Multi tube needle	14G-28G	13mm	25.4mm	38mm	support
06	Detachable large base threaded needle	14G-28G	13mm	25.4mm	38mm	support
07	Large base double threaded needle head	14G-28G	13mm	25.4mm	38mm	support

Note: The above data may have slight errors due to manual measurement

# Plastic steel double tube needle head

Plastic steel double tube needle head



## Product information

Product Name: Plastic Steel Double Tube Needle

Product application: Can be paired with needle cylinder, dispensing valve, and various adapters

Needle material: Plastic+stainless steel

## Parameters of plastic steel double tube needle head

Model number	Total length		Outside diameter	Inside diameter	Needle spacing	Exposed length	
	½ Inch	1Inch				½ Inch	1Inch
18G	30.8mm	43mm	1.24mm	0.84mm	1.2mm	13mm	25.4mm
19G	30.8mm	43mm	1mm	0.7mm	1.2mm	13mm	25.4mm
20G	30.8mm	43mm	0.9mm	0.6mm	1.6mm	13mm	25.4mm
21G	30.8mm	43mm	0.8mm	0.5mm	1.7mm	13mm	25.4mm
22G	30.8mm	43mm	0.7mm	0.4mm	1.8mm	13mm	25.4mm
23G	30.8mm	43mm	0.6mm	0.3mm	1.8mm	13mm	25.4mm
24G	30.8mm	43mm	0.55mm	0.27mm	2mm	13mm	25.4mm
25G	30.8mm	43mm	0.5mm	0.25mm	2mm	13mm	25.4mm
26G	30.8mm	43mm	0.45mm	0.22mm	2.1mm	13mm	25.4mm
27G	30.8mm	43mm	0.4mm	0.2mm	2.1mm	13mm	25.4mm

Note: The above data may have slight errors due to manual measurement

# Brush Needle

## Round Mouth Brush Needle



## Flat Mouth Brush Needle

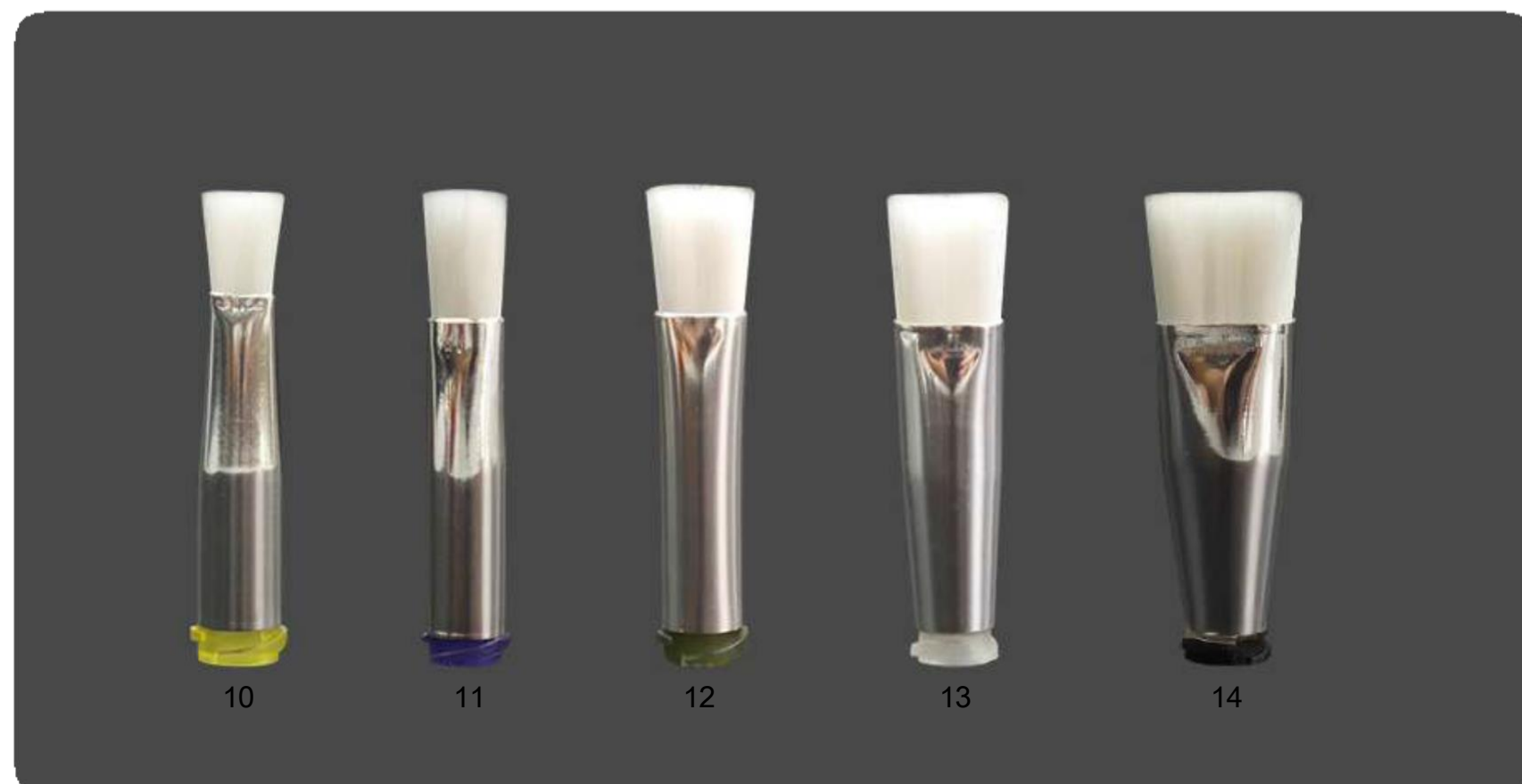

## Product information

Product Name: Brush Needle

Needle material: Aluminum+nylon

Product customization: Supports aluminum tube extension, sponge head bristles, and plastic sleeve Soft brush hair. 3-8mm brush needle can be customized with a flat head

## Brush needle parameters

Serial Number	Needle model	Available models	Exposed length of brush	Total length	Aluminum tube length	Gross width
01	1mm sponge	19G~34G	6mm	36mm	30mm	1mm
02	1mm round mouth	20G~27G	8.2mm	39mm	30.8mm	1mm
03	2mm round mouth	20G~34G	7mm	37mm	30mm	2mm
04	3mm round mouth	16G~34G	9mm	39mm	30mm	3mm
05	4mm round mouth	14G~34G	8/10mm	38/40mm	30mm	4mm
06	5mm round mouth	14G~34G	8/10mm	38/40mm	30mm	5mm
07	6mm round mouth	14G~34G	7/10mm	37/40mm	30mm	6mm
08	8mm round mouth	16G~34G	9mm	40mm	31mm	8mm
09	10mm round mouth	15G~34G	10mm	40mm	30mm	10mm
10	5mm flat mouth	14G~34G	8/10mm	38/40mm	30mm	5mm
11	6mm flat mouth	14G~34G	8/10mm	38/40mm	30mm	6mm
12	7mm flat mouth	14G~34G	8/10mm	38/40mm	30mm	7mm
13	10mm flat mouth	14G~34G	8/10mm	38/40mm	30mm	10mm
14	12mm flat mouth	14G~34G	13mm	39.3mm	26.3mm	12mm

Note: The above data may have slight errors due to manual measurement

Inner diameter of glue discharge: The inner diameter of glue discharge for needles of the same model is the same, including: the inner diameter of glue discharge for 19G brush needles and 19G plastic steel needles is 0.72mm Brush needle model parameters (next page)

## Brush needle model parameters

Model number	Colour	Inner diameter of adhesive discharge	Can withstand pressure	Introduction to Brush Needle Products
14G	Olive color	1.05mm	100PSI	Nylon material, made of soft wool. High quality needles are used for all glue guns, pneumatic glue dispensers, glue valves, and desktop glue dispensers, capable of withstanding a pressure of 100PSI. They are suitable for primers, catalysts, coating materials, lubricants, solvents, flux, heat dissipation paste, silicone, ink, and paint. Not suitable for quick drying adhesives and high viscosity colloids. The specifications include 14G 15G 16G 17G 18G 20G 21G 22G 23G 24G 25G 26G 27G 30G 32G 34G in large quantities in stock.
15G	Amber	1.43mm	100PSI	
16G	Grey	1.25mm	100PSI	
17G	Light brown	1.11mm	100PSI	
18G	Green	0.84mm	100PSI	
19G	Black	0.72mm	100PSI	
20G	Pink	0.61mm	100PSI	
21G	Purple	0.52mm	100PSI	
22G	Blue	0.42mm	100PSI	
23G	Orange	0.34mm	100PSI	
24G	Peach red	0.30mm	100PSI	
25G	Red	0.26mm	100PSI	
26G	Light Orange	0.25mm	100PSI	
27G	Transparent color	0.21mm	100PSI	
30G	Light Purple	0.16mm	100PSI	
32G	Yellow	0.11mm	100PSI	
34G	Light purple	0.06mm	100PSI	

## Round mouth bristle brush needle

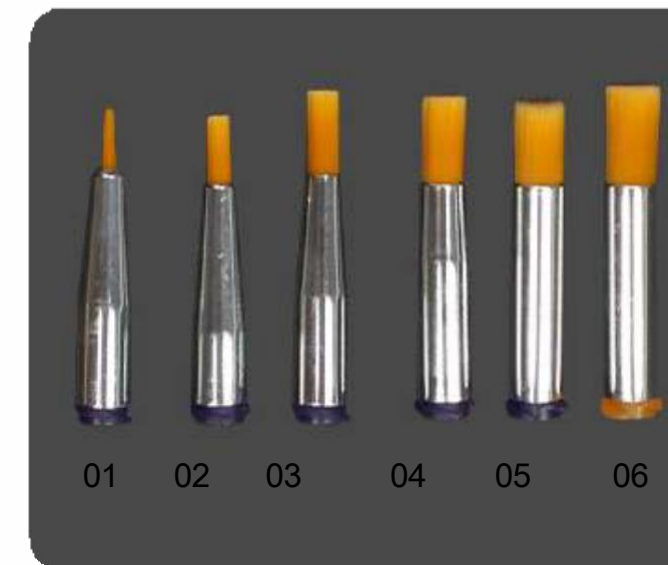

Product name: Round mouth hard bristle brush needle Product model: 21G/23G  
 Product Material: Aluminum+Nylon  
 Product customization: Support aluminum tube extension, sponge head brush cat, plastic sleeve sponge head brush hair.  
 The 3-8mm brush needle can be customized with a flat head.  
 Product application: primer, catalyst, coating material, lubricating oil, solvent, soldering aid  
 Agent, heat dissipation paste, silicone, ink, and paint.

## Round mouth bristle brush needle

Serial Number	Needle model	Model number	Total length	Aluminum tube length	Gross width	Inner diameter of adhesive discharge
01	2mm round bristle brush needle	21G	38mm	28.5mm	2mm	0.5mm
02	3mm round bristle brush needle	21G	37mm	26.5mm	3mm	0.5mm
03	4mm round bristle brush needle	21G	40mm	27.7mm	4mm	0.5mm
04	5mm round bristle brush needle	21G	39mm	26.3mm	5mm	0.5mm
05	6mm round bristle brush needle	21G	40mm	26.4mm	6mm	0.5mm
06	6mm round bristle brush needle	23G	40mm	26.5mm	6mm	0.3mm

Note: The above data may have slight errors due to manual measurement

# Teflon needle

1/2/ 1 Inch Teflon Needle



## Teflon needle parameters

Name	Colour	Total length	Outer diameter of stainless steel pipe	Outer diameter of Teflon tube	Inner diameter of Teflon tube
20G Teflon Needle Half Inch	Grey	33.5mm	1.64mm	1.14mm	0.6mm
25G Teflon Needle Half Inch	Pink	33.5mm	1.28mm	0.8mm	0.33mm
27G Teflon Needle Half Inch	Red	33.5mm	0.9mm	0.6mm	0.25mm
20G Teflon needle 1 inch	Grey	45.5mm	1.64mm	1.14mm	0.6mm
25G Teflon needle 1 inch	Pink	45.5mm	1.28mm	0.8mm	0.33mm
27G Teflon Needle 1 inch	Red	45.5mm	0.9mm	0.6mm	0.25mm

Note: The above data may have slight errors due to manual measurement

## Product characteristics

1. For the use of fast drying glue to operate the factory, Teflon needle is the best choice. Teflon is non-sticky and prevents the quick-drying glue from curing inside the needle.
2. The needle made of high-quality Teflon material, in the smooth and non-viscous performance is quite good, the outer layer of stainless steel tube guide, can accurately meet the requirements of the glue.

## Product mix

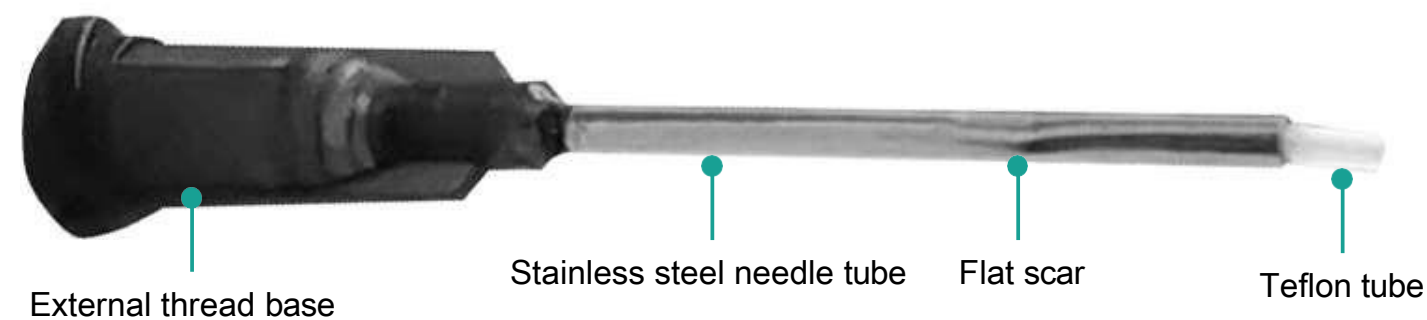

Flat marks: Teflon needles are divided into those with flat marks and those without flat marks.

Flat marks refer to the needle tip being pressed by the machine, which has the effect of preventing the Teflon tube from falling off and also has a certain impact on the adhesive output.

No flat marks indicate that the needle has not been pressed by the machine, and there is a slight risk of falling off the Teflon tube, which does not affect the adhesive output.

## Product information

Product name: Teflon needle

Needle material: Plastic steel needle + Teflon tube Product

customization: Support customization

# Aluminum inlaid needle

Note: The above data may have slight errors due to manual measurement

Colour	Total length	Outside diameter	Inside diameter	Exposed length	Custom head
Purple	31.6mm	0.31mm	0.16mm	13mm	support
Yellow	31.6mm	0.23mm	0.11mm	13mm	support



## Product information

Product Name: Aluminum Inlaid Plastic Steel Screw Mouth Needle  
 Needle material: Plastic+stainless steel+aluminum  
 Product customization: Needle length supports customization

## Parameters of aluminum inlaid plastic steel threaded needle head

Model number	Colour	Total length	Outside diameter	Inside diameter	Exposed length	Custom
14G	Olive	31.6mm	2.0mm	1.80mm	13mm	support
15G	Amber	31.6mm	1.83mm	1.43mm	13mm	support
16G	Grey	31.6mm	1.65mm	1.25mm	13mm	support
18G	Green	31.6mm	1.28mm	0.84mm	13mm	support
20G	Pink	31.6mm	0.91mm	0.61mm	13mm	support
21G	Purple	31.6mm	0.81mm	0.51mm	13mm	support
22G	Blue	31.6mm	0.71mm	0.41mm	13mm	support
23G	Orange	31.6mm	0.64mm	0.33mm	13mm	support
25G	Red	31.6mm	0.51mm	0.25mm	13mm	support
27G	Transparent	31.6mm	0.41mm	0.21mm	13mm	support

Note: The above data may have slight errors due to manual measurement

## Bayonet type all aluminum

## base needle



Product name: 18G all aluminum base bayonet metal needle Product model: 18G  
 Total length: 28mm  
 Needle tube outer diameter: 1.28mm  
 Needle tube inner diameter: 0.84mm  
 Exposed length: 28mm  
 Inner diameter of base interface: 4.2mm Outer diameter of base interface: 7.6mm

## product description

Plastic seat aluminum inlaid dispensing needle: This series of dispensing needles is designed with double threads on the base of conventional dispensing, and aluminum inlaid riveting is used between the stainless steel needle tube and the poly-ethylene needle base to improve tensile resistance. Avoiding the risk of adhesive breakage and corrosion of certain liquids in conventional dispensing needles, thereby improving the service life of the needle to a certain extent.

# Sheath tip needle

Note: The above data may have slight errors due to manual measurement

Model number	Total length	Outside diameter	Inside diameter	Exposed length	Package
Transparent 16 size X38MM	55mm	1.65mm	1.25mm	38mm	bulk
Transparent size					
# 20G screw					



## Product information

Product Name: Plastic Steel Sheath Pointed Needle  
 Needle material: Plastic+stainless steel

Product customization: Needle length supports customization  
 Product packaging: Independent packaging (sterile needles)/bulk

## Parameters of bulk plastic steel sheath needle tip

Model number	Total length	Outside diameter	Inside diameter	Exposed length	Package
Light gray size 4 X13MM	30mm	0.42mm	0.21mm	13mm	bulk
Brown size 4.5 X16MM	33mm	0.46mm	0.25mm	16mm	bulk
Orange No.5 X20MM	37mm	0.52mm	0.26mm	20mm	bulk
Purple 5.5 size X25MM	42mm	0.55mm	0.3mm	25mm	bulk
Blue No.6 X25MM	42mm	0.64mm	0.34mm	25mm	bulk
Light black size 7 X30MM	47mm	0.72mm	0.42mm	30mm	bulk
Green No.8 X35MM	52mm	0.82mm	0.52mm	35mm	bulk
Yellow No.9 X38MM	55mm	0.92mm	0.61mm	38mm	bulk
Milky white size 10 X38MM	55mm	1.08mm	0.72mm	38mm	bulk
Pink 12 size X38MM	55mm	1.28mm	0.84mm	38mm	bulk

Note: The above data may have slight errors due to manual measurement

## Conventional independent packaging needle tip parameters

Model number	Total length	Outside diameter	Inside diameter	Exposed length	Independent packaging
Brown size 4.5 X16MM	33mm	0.46mm	0.25mm	16mm	yes
Orange No.5 X20MM	37mm	0.52mm	0.26mm	20mm	yes
Orange No.5 X38MM	55mm	0.52mm	0.26mm	38mm	yes
Blue No.6 X25MM	42mm	0.64mm	0.34mm	25mm	yes
Light black size 7 X30MM	47mm	0.72mm	0.42mm	30mm	yes
Green No.8 X38MM	55mm	0.82mm	0.52mm	38mm	yes
Yellow No.9 X38MM	55mm	0.92mm	0.61mm	38mm	yes
Pink size 12 X30MM	47mm	1.28mm	0.84mm	30mm	yes
Transparent color 16 size X30MM	47mm	1.65mm	1.25mm	30mm	yes

Note: The above data may have slight errors due to manual measurement

## 30G Individually packaged ultrafine pointed small needles

Model number	Total length	Outside diameter	Inside diameter	Exposed length	Independent packaging
Light yellow 30GX4MM	21mm	0.31mm	0.16mm	4mm	yes
Light yellow 30GX13MM	30mm	0.31mm	0.16mm	13mm	yes
Light yellow 30GX25MM	42mm	0.31mm	0.16mm	25mm	yes

Note: The above data may have slight errors due to manual measurement

## Product description

Plastic steel bayonet needle, needle stainless steel, base plastic material is durable, often used in industrial dispensing, teaching experiments, etc., all steel pipe needles are using no burr processing technology, liquid discharge accuracy is high, no wire clogging, drawing, needle holder using bayonet design, only make more safe, and easier to disassemble

# Animal needle

## Stainless steel pointed animal needle



### Product information

Product Name: Beast Pointed Needle

Product customization: Needle length and diameter support customization

Needle material: Copper nickel plating+stainless steel

Product packaging: 10 pieces/box

### Parameters of conventional animal pointed needles

Model number	Total length	Outside diameter	Inside diameter	Exposed length	Package
NO.4	31mm	0.4mm	0.2mm	20mm	10 pieces/box
NO.4.5	31mm	0.45mm	0.22mm	20mm	10 pieces/box
NO.5	31mm	0.5mm	0.25mm	20mm	10 pieces/box
NO.5.5	34mm	0.55mm	0.27mm	23mm	10 pieces/box
NO.6	41mm	0.6mm	0.3mm	30mm	10 pieces/box
NO.7	46mm	0.7mm	0.4mm	35mm	10 pieces/box
NO.8	46mm	0.8mm	0.5mm	35mm	10 pieces/box
NO.9	46mm	0.9mm	0.6mm	35mm	10 pieces/box
NO.10	46mm	1.02mm	0.72mm	35mm	10 pieces/box
NO.12	46mm	1.26mm	0.86mm	35mm	10 pieces/box

Note: The above data may have slight errors due to manual measurement

Model number	Total length	Outside diameter	Inside diameter	Exposed length	Package
No.14	46mm	1.5mm	1.05mm	35mm	10 pieces/box
No.16	46mm	1.6mm	1.15mm	35mm	10 pieces/box
No.18	46mm	1.78mm	1.3mm	35mm	10 pieces/box
No.20	46mm	2.08mm	1.55mm	35mm	10 pieces/box

Note: The above data may have slight errors due to manual measurement

Model number	Total length	Outside diameter	Inside diameter	Exposed length	Package
No. 5 exposed 26	37mm	0.5mm	0.25mm	26mm	10 pieces/box
No. 8 exposed 40	60mm	0.8mm	0.5mm	40mm	10 pieces/box
No. 9 exposed 15	26mm	0.9mm	0.6mm	15mm	10 pieces/box
No. 12 exposed 40	51mm	1.26mm	0.86mm	40mm	10 pieces/box
No. 12 exposed 50	61mm	1.26mm	0.86mm	50mm	10 pieces/box
No.18 exposed 13	25mm	1.26mm	0.86mm	13mm	10 pieces/box
No. 20 exposed 13	25mm	0.9mm	0.6mm	13mm	10 pieces/box
No.20 exposed 50	61mm	2.08mm	1.55mm	50mm	10 pieces/box
No.24 exposed 9.5	21.5mm	0.55mm	0.27mm	9.5mm	10 pieces/box

Note: The above data may have slight errors due to manual measurement

### Product description

Base male sows must use a 16-gauge needle, the length must be more than 38MM, (boars less than or equal to 1.5 years old, can use 16\*38MM metal needle, boars more than 1.5 years old 45MM, gilts 35-40MM, at least 38MM partrimester sow) piglets less than 25 kg, the general length is less than 25MM, Fattening pigs 25-110 kg, length must be more than 25MM, subcutaneous injection: 12\*20-25MM. Conventional pigs under 30 kg use a 9 gauge needle, 30-60 kg use a 12 gauge needle, and more than 60 kg use a 16 gauge needle. Special attention: pig iron injection with 7 needle, advance immunization selected 9 needle.

The advantages of stainless steel needles: excellent material, no rust can be disinfected, repeated use of the needle is strong and durable, tightly bonded and does not leak.

# Metal external thread needle

M3~M8 ; G1/8 ; G1/4 ; NPT external thread needle



## Product information

Product Name: Metal External Thread Needle

Needle material: Copper nickel plating+stainless steel

Product customization: The needle tube customization range is 8G~20G, which can be made into single tube and double tube

Customization standard: Minimum of 5 NPT orders

## Metal external thread needle

Name	Available models	Exposed length			Length customization
		½ inch	1 inch	1.5 inches	
M3 external thread needle	8G~20G	13mm	25.4mm	38mm	support
M4 external thread needle	8G~20G	13mm	25.4mm	38mm	support
M5 external thread needle	8G~20G	13mm	25.4mm	38mm	support
M6 external thread needle	8G~20G	13mm	25.4mm	38mm	support
M8 external thread needle	8G~20G	13mm	25.4mm	38mm	support
M10 external thread needle	8G~20G	13mm	25.4mm	38mm	support
G1/8 external thread	8G~20G	13mm	25.4mm	38mm	support
G1/4 external thread	8G~20G	13mm	25.4mm	38mm	support
NPT external thread	8G~20G	13mm	25.4mm	38mm	support

Note: The above data may have slight errors due to manual measurement

## G1/8; G1/4 external thread large pointed needle head



Serial Number	Name	Outside diameter	Inside diameter	Total length	Thread diameter
01	G1/8 thread exposed length 50mm	6mm	5mm	65mm	9.5mm
02	G1/8 thread exposed length 80mm	6mm	5mm	95mm	9.5mm
03	G1/8 thread exposed length 100mm	6mm	5mm	115mm	9.5mm
04	G1/8 thread exposed length 150mm	6mm	5mm	165mm	9.5mm
05	G1/4 thread exposed length 50mm	6mm	5mm	68.6mm	13mm
06	G1/4 thread exposed length 80mm	6mm	5mm	98.6mm	13mm
07	G1/4 thread exposed length 100mm	6mm	5mm	118.6mm	13mm
08	G1/4 thread exposed length 150mm	6mm	5mm	168.6mm	13mm

Note: The above data may have slight errors due to manual measurement

## Product description

The difference between NPT and conventional thread is that the base of NPT is tightened with taper, and the thread can only be twisted half into it.



# Metal double threaded needle head

Metal double thread needle

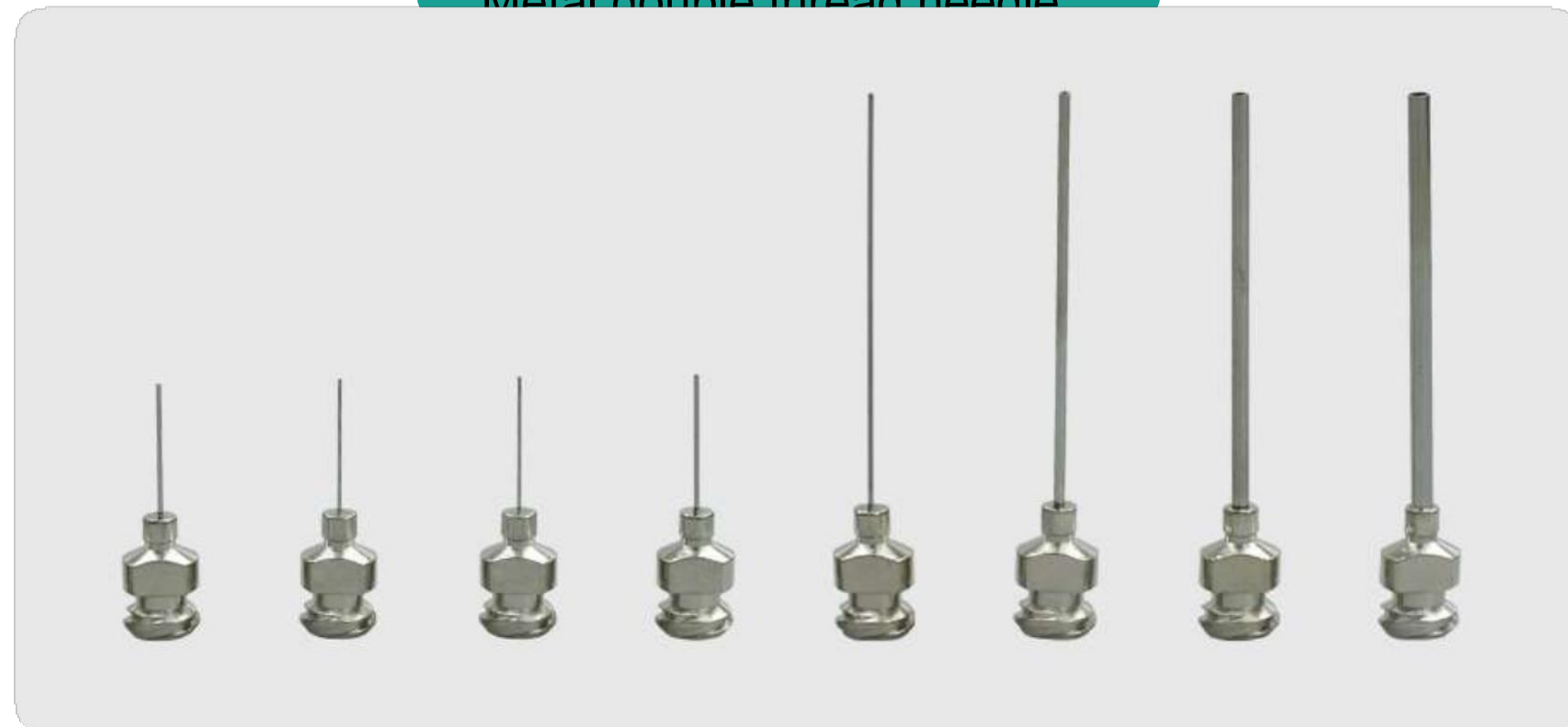

## Product information

Product Name: Metal Double Thread Needle

Product customization: Needle tube customization range 8G~32G

Needle material: Stainless steel

Product packaging: 10 pieces/box

## Metal double threaded needle head

Name	Total length		Outside diameter	Inside diameter	Exposed length		Wall thickness
	½ Inch	1.5 Inches			½ Inch	1.5 Inches	
8G	25mm	50mm	4mm	3.5mm	13mm	38mm	0.25mm
10G	25mm	50mm	3.45mm	2.85mm	13mm	38mm	0.3mm
11G	25mm	50mm	2.95mm	2.45mm	13mm	38mm	0.25mm
12G	25mm	50mm	2.8mm	2.3mm	13mm	38mm	0.25mm
13G	25mm	50mm	2.4mm	1.9mm	13mm	38mm	0.25mm
14G	25mm	50mm	2.08mm	1.55mm	13mm	38mm	0.25mm
15G	25mm	50mm	1.78mm	1.3mm	13mm	38mm	0.25mm
16G	25mm	50mm	1.6mm	1.15mm	13mm	38mm	0.2mm
17G	25mm	50mm	1.5mm	1.05mm	13mm	38mm	0.2mm
18G	25mm	50mm	1.26mm	0.86mm	13mm	38mm	0.2mm
19G	25mm	50mm	1.02mm	0.72mm	13mm	38mm	0.15mm

Note: The above data may have slight errors due to manual measurement

Name	Total length		Outside diameter	Inside diameter	Total length		Wall thickness
	½ Inch	1.5 Inches			½ Inch	1.5 Inches	
20G	25mm	50mm	0.9mm	0.6mm	13mm	38mm	0.15mm
21G	25mm	50mm	0.8mm	0.5mm	13mm	38mm	0.15mm
22G	25mm	50mm	0.7mm	0.4mm	13mm	38mm	0.15mm
23G	25mm	50mm	0.6mm	0.3mm	13mm	38mm	0.15mm
24G	25mm	50mm	0.55mm	0.27mm	13mm	38mm	0.155mm
25G	25mm	50mm	0.5mm	0.25mm	13mm	38mm	0.125mm
26G	25mm	50mm	0.45mm	0.22mm	13mm	38mm	0.125mm
27G	25mm	50mm	0.4mm	0.2mm	13mm	38mm	0.125mm
28G	25mm	50mm	0.32mm	0.17mm	13mm	38mm	0.075mm
30G	25mm	50mm	0.3mm	0.15mm	13mm	38mm	0.075mm
32G	25mm	50mm	0.24mm	0.1mm	13mm	38mm	0.08mm

Note: The above data may have slight errors due to manual measurement

# Side hole needle head

Metal/plastic steel/special side hole needle head



## Product information

Product Name: Side Hole Needle  
Product packaging: 10 pieces/box

Product customization: Needle tube customization range 8G~20G  
Needle material: Plastic/copper nickel plating+stainless steel

## Side hole needle head

Name	Needle outer diameter	Total length of needle	Exposed dimensions	Base diameter	Total length of base	Inner diameter of base
No.5	0.5mm	43mm	30mm	7mm	12.7mm	4mm
No.5 (pointed)	0.5mm	43mm	30mm	7mm	12.7mm	4mm
No.5	0.5mm	53mm	40mm	7mm	12.7mm	4mm
No.5	0.5mm	73mm	60mm	7mm	12.7mm	4mm
No.7	0.7mm	60mm	50mm	7mm	12.7mm	4mm
No.7	0.7mm	113mm	100mm	7mm	12.7mm	4mm
No.9	0.9mm	63mm	50mm	7mm	12.7mm	4mm
No.9	0.9mm	113mm	100mm	7mm	12.7mm	4mm
No.10	1.02mm	51mm	38mm	7mm	12.7mm	4mm
No. 12 (plastic steel)	1.26mm	49mm	32mm	7.6mm	17mm	4.2mm
No. 12 (plastic steel)	1.26mm	55mm	38mm	7.6mm	17mm	4.2mm

Note: The above data may have slight errors due to manual measurement

Name	Needle outer diameter	Total length of needle	Exposed dimensions	Base diameter	Total length of base	Inner diameter of base
No.12	1.26mm	51mm	38mm	7mm	12.7mm	4mm
No.12	1.26mm	53mm	40mm	7mm	12.7mm	4mm
No. 16 (plastic steel)	1.6mm	47mm	30mm	7.6mm	17mm	4.2mm
No.16	1.6mm	43mm	30mm	7mm	12.7mm	4mm
No.16	1.6mm	53mm	40mm	7mm	12.7mm	4mm
No.16	1.6mm	133mm	120mm	7mm	12.7mm	4mm
No.20	2.08mm	113mm	100mm	7mm	12.7mm	4mm

Note: The above data may have slight errors due to manual measurement

## Special metal side hole needle head

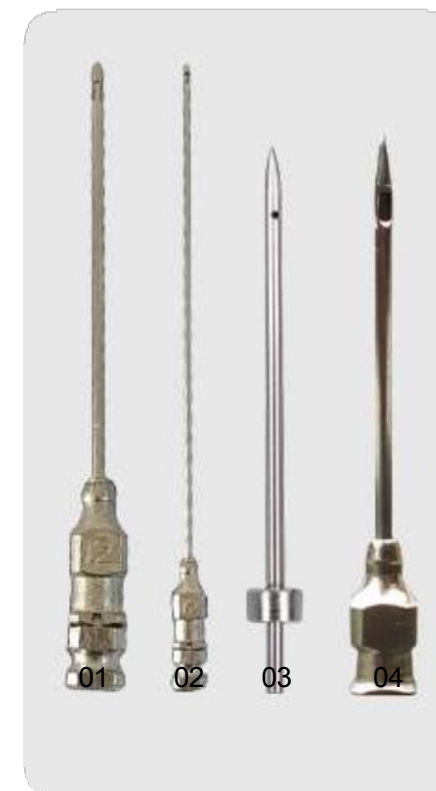

Product Name: Side Hole Needle  
Product material: Copper nickel plating+stainless steel Product  
customization: Supports customization of other sizes Product  
packaging: 10 pieces/box

Serial Number	Name	Total length	Needle outer diameter	Exposed length
01	12 # needle with solid push pin and round head side hole	73mm	1.26mm	50mm
02	12 # needle with solid push pin and round head side hole	124mm	1.26mm	100mm
03	12 # metal side hole needle head	41mm	1.02mm	38mm
04	M5 internal thread side hole needle head	47mm	1.6mm	33.5mm

Note: The above data may have slight errors due to manual measurement

## External thread side hole needle head



Product Name: External Thread Side Hole Needle Product  
material: Stainless steel  
Total length: 53mm  
Needle outer diameter: 3mm Exposed length: 34mm  
Through perforation: Diameter 2mm  
Thread diameter: 12.3mm (G 1/4 )  
Hexagonal diameter: 11mm

# Extended and thickened needle head

Pointed/flat needle



## Product information

Product Name: Extended and Bold Needle  
 Needle material: Copper nickel plating+stainless steel  
 Product customization: Needle customization range 8G~12G, pointed flat head are supported customization

## Long and thick needle

Name	Needle outer diameter	Needle inner diameter	Exposed size (mm)	Syringe needle
8G	4mm	3.5mm	60/80/100/120/150/200mm	Pointed/Flat
10G	3.45mm	2.85mm	60/80/100/120/150/200mm	Pointed/Flat
11G	2.95mm	2.45mm	60/80/100/120/150/200/250mm	Pointed/Flat
12G	2.8mm	2.3mm	60/80/100/108/120/150/180/200/241/250mm	Pointed/Flat

Note: The above data may have slight errors due to manual measurement

# High precision needle

## High precision needle (extended)



Product Name: High Precision Needle (Extended) Needle  
 material: Copper nickel plated/stainless steel Thread size:  
 M3.5 thread  
 Mouth extension: 2-4mm

Due to the conical shape of the needle, there may be deviations in the outer diameter depending on the measurement position

## High precision needle (extended)

Serial Number	Name	Total length	Needle outer diameter	Needle inner diameter	Extend the exposed length of the nozzle
01	HN-0.4	10.7mm	0.7mm	0.4mm	2mm
02	HN-0.4	13.7mm	0.7mm	0.4mm	4mm
03	HN-0.6	11mm	0.9mm	0.6mm	2mm
04	HN-0.6	12mm	0.9mm	0.6mm	4mm

Note: The above data may have slight errors due to manual measurement

## High precision needle base



Product name: High precision needle base  
 Base material: 05-06 (copper nickel plated)  
 07-08 (stainless steel)  
 Base length: 05 (15.2mm); 06 (15.4mm)  
 07 (14.3mm); 08 (15.2mm)  
 Base interface: 05-07 (threaded port) 06-08 (bayonet)  
 Base weight: 05 (2.4g) 06 (1.6g) 07 (1.75g)  
 08 (1.65g)

## Characteristics of split type high-precision needle head

### Product and technical characteristics

1. The improvement of the glue mouth: different from the general manufacturing technology, the use of the company's patented technology can be thin wall treatment of the glue mouth, so that smaller caliber products have a larger flow; And to a greater extent, the occurrence probability of wire hanging and glue blocking caused by the accumulation of the needle tip.
2. Tip lengthening customization: The company according to the special needs of customers, can develop the tip lengthening products.
3. Special product surface polishing technology: special product surface treatment technology, can further improve the smoothness of the product, improve the smoothness of the product surface, make the dispensing material through more smooth, improve the service life of the product.
4. Product specifications: general base, needle tip and split dispensing single needle specifications are consistent (P3-4).
5. Product linear appearance picture: see (Figure 1) screw; (Figure 2) Bayonet.

### Material: SUS- imported stainless steel

Suitable equipment: Musashi Han Sejong Winison Tensheng and other Luer interface valve body dispensing machine.

### Application industry

Dispensing needles are mainly used in SMT, LED, semiconductor manufacturing, medicine and other dispensing industries.

### Using media

1. All kinds of adhesives, phosphors, silicone, two-component glue, instant drying glue, water-soluble glue, etc.
2. All kinds of solder paste, conductive glue, RTV glue, epoxy glue, anaerobic glue, polyurethane and so on.
3. All kinds of coatings, additives, emulsions, sticky raw materials, paints, oils.
4. A variety of high viscosity UV glue, optical glue.

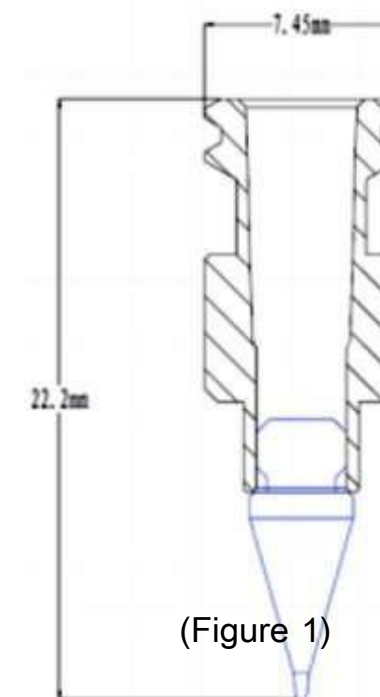

(Figure 1)

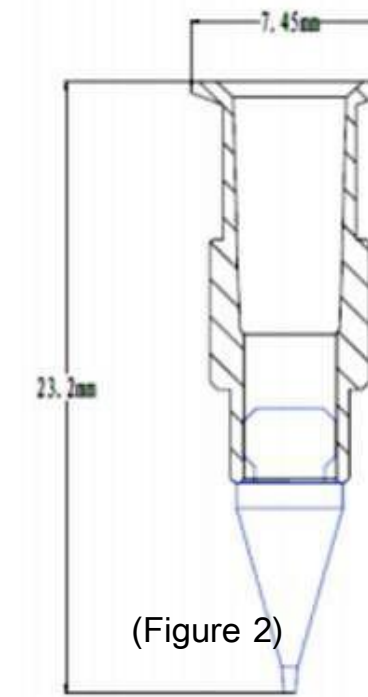

(Figure 2)

# High precision integrated bayonet needle

## High precision integrated bayonet needle



### High precision integrated bayonet needle

Model number	Inside diameter	Outside diameter	Total length
SHN-0.15	0.15mm	0.45mm	18.3mm
SHN-0.2	0.2mm	0.5mm	18.3mm
SHN-0.25	0.25mm	0.55mm	18.3mm
SHN-0.3	0.3mm	0.6mm	18.3mm
SHN-0.4	0.4mm	0.7mm	18.3mm
SHN-0.45	0.45mm	0.75mm	18.3mm
SHN-0.5	0.5mm	0.8mm	18.3mm
SHN-0.6	0.6mm	0.9mm	18.3mm

Note: The above data may have slight errors due to manual measurement

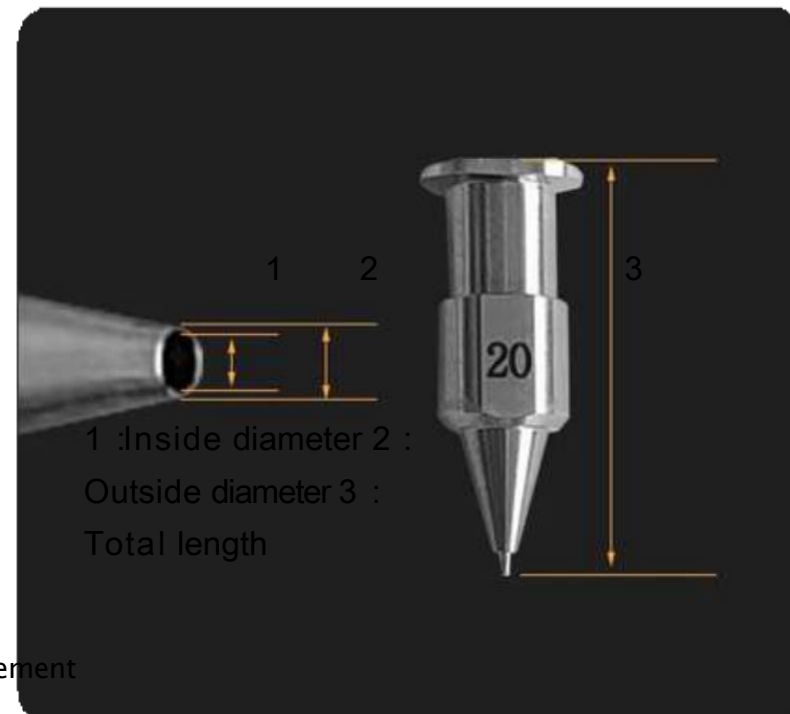

## Characteristics of high-precision needles

### Product overview

1. Integrated structure, eliminating the installation of nozzle operations.
2. Cone shape to achieve superior flow characteristics.
3. Through the ultra-thin processing of the nozzle, to achieve high precision micro stable dispensing.
5. Product linear appearance picture: see (Figure 1)

### Material: SUS- imported stainless steel

Suitable equipment: Musashi Han Sejong Winison Tensheng and other Luer interface valve body dispensing machine.

### Application industry

Dispensing needles are mainly used in SMT, LED, semiconductor manufacturing, medicine and other dispensing industries.

### Using media

1. All kinds of adhesives, phosphors, silicone, two-component glue, instant drying glue, water-soluble glue, etc.
2. All kinds of solder paste, conductive glue, RTV glue, epoxy glue, anaerobic glue, polyurethane and so on.
3. All kinds of coatings, additives, emulsions, sticky raw materials, paints, oils.
4. A variety of high viscosity UV glue, optical glue.

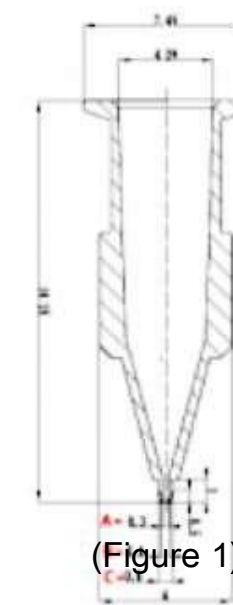

(Figure 1)

# High precision integrated threaded needle head

## High precision integrated threaded needle head



### High precision integrated threaded needle head

Model number	Inside diameter	Outside diameter	Total length
SHN-0.2S	0.2mm	0.5mm	18.3mm
SHN-0.25S	0.25mm	0.55mm	18.3mm
SHN-0.3S	0.3mm	0.6mm	18.3mm
SHN-0.4S	0.4mm	0.7mm	18.3mm
SHN-0.45S	0.45mm	0.75mm	18.3mm
SHN-0.5S	0.5mm	0.8mm	18.3mm
SHN-0.6S	0.6mm	0.9mm	18.3mm

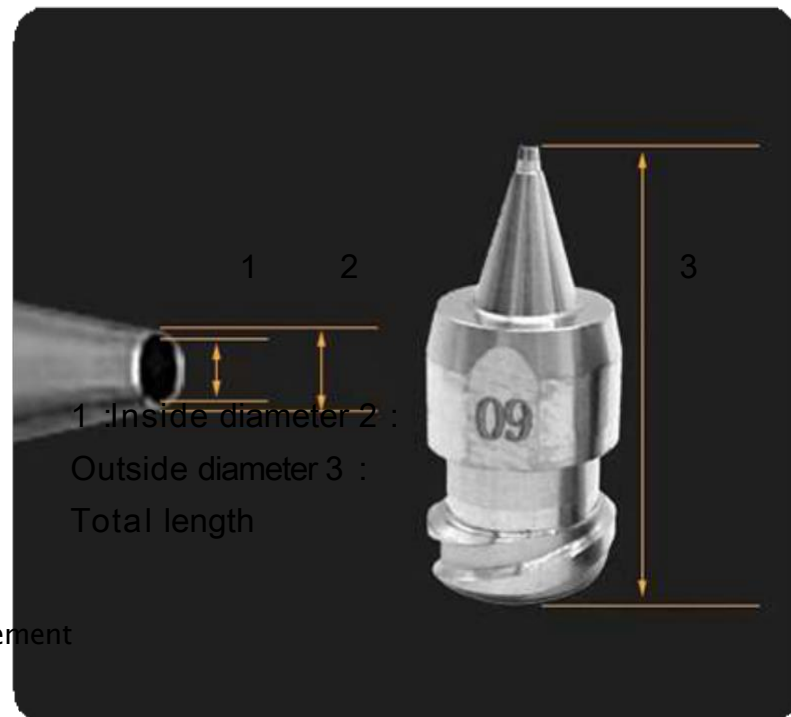

Note: The above data may have slight errors due to manual measurement

## Characteristics of high-precision needles

### Product overview

1. Integrated structure, eliminating the installation of nozzle operations.
2. Cone shape to achieve superior flow characteristics.
3. Through the ultra-thin processing of the nozzle, to achieve high precision micro stable dispensing.
5. Product linear appearance picture: see (Figure 1).

**Material: SUS- imported stainless steel**

Suitable equipment: Musashi Han Sejong Winison Tensheng and other Luer interface valve body dispensing machine.

### Application industry

Dispensing needles are mainly used in SMT, LED, semiconductor manufacturing, medicine and other dispensing industries.

### Using media

1. All kinds of adhesives, phosphors, silicone, two-component glue, instant drying glue, water-soluble glue, etc.
2. All kinds of solder paste, conductive glue, RTV glue, epoxy glue, anaerobic glue, polyurethane and so on.
3. All kinds of coatings, additives, emulsions, sticky raw materials, paints, oils.
4. A variety of high viscosity UV glue, optical glue.

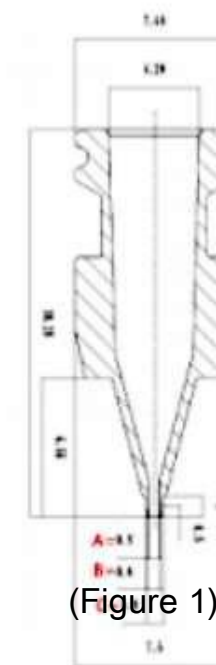

# Winnison split needle

Winnison needle ( 0.3MM~0.8mm )



## Winnison split needle

1. Total length of needle: 13mm
2. Diameter of the thickest needle tip: 3mm
3. Diameter at needle interface: 2mm
4. Inner diameter at needle interface: 1.47mm
5. Needle inner diameter: 0.3mm; 0.4mm; 0.5mm; 0.6mm; 0.7mm; 0.8mm

Note: The data may have some errors due to manual measurement

The needle can be customized with a coating.

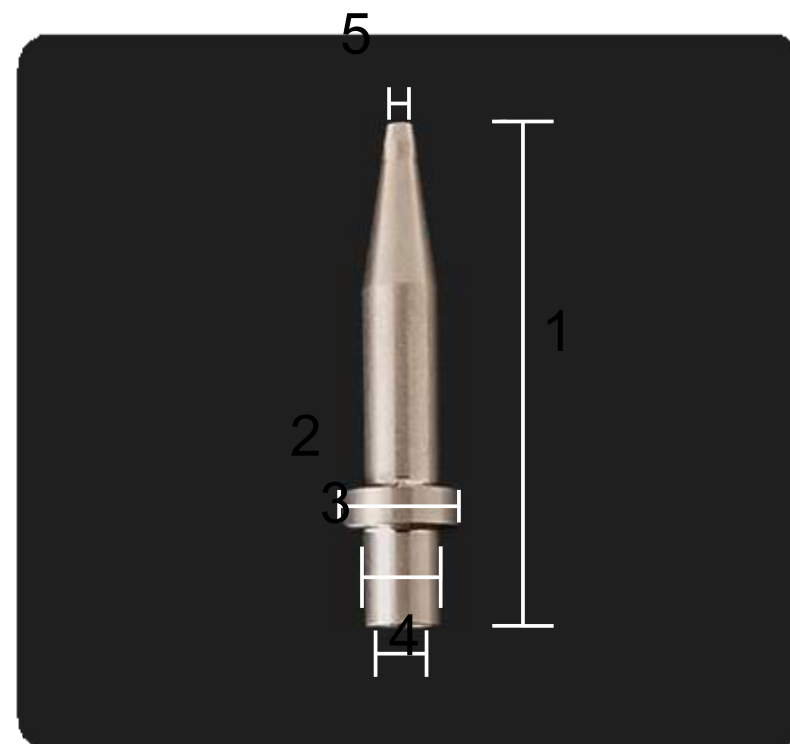

## Characteristics of the Weinison split needle

Material: SUS- imported stainless steel

Product size: Bottom interface diameter 2.0mm total length 13mm

Outlet size: 0.3mm; 0.35mm; 0.4mm; 0.5mm; 0.6mm; 0.7mm; 0.8mm.

Suitable for equipment: Vinisen Xinlong Bang Wanhe Pulong long Sunshine Changlin Huerxin Alais and other multi-head high-speed dispensing machine.

Product line appearance picture: see (Figure 1)

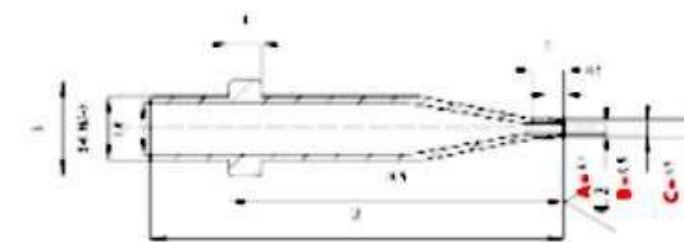

(Figure 1)

# Hexagonal base soldering needle

Hexagonal base soldering needle



## Product information

Product Name: Hexagonal Base Internal Thread Solder Needle Needle

material: Copper nickel plating+stainless steel+tin

Product customization: Needle length and thickness support customization Base

thread: M5

## Hexagonal base internal thread solder needle

Name	Total length	Inside diameter	Outside diameter	Exposed length	Outer diameter of base	Inner diameter of base
16G	23mm	1.15mm	1.6mm	10mm	6.7mm	4.2mm
18G	23mm	0.86mm	1.2mm	10mm	6.7mm	4.2mm

Note: The above data may have slight errors due to manual measurement

# Stainless steel gastric lavage needle

Rat gastric lavage needle

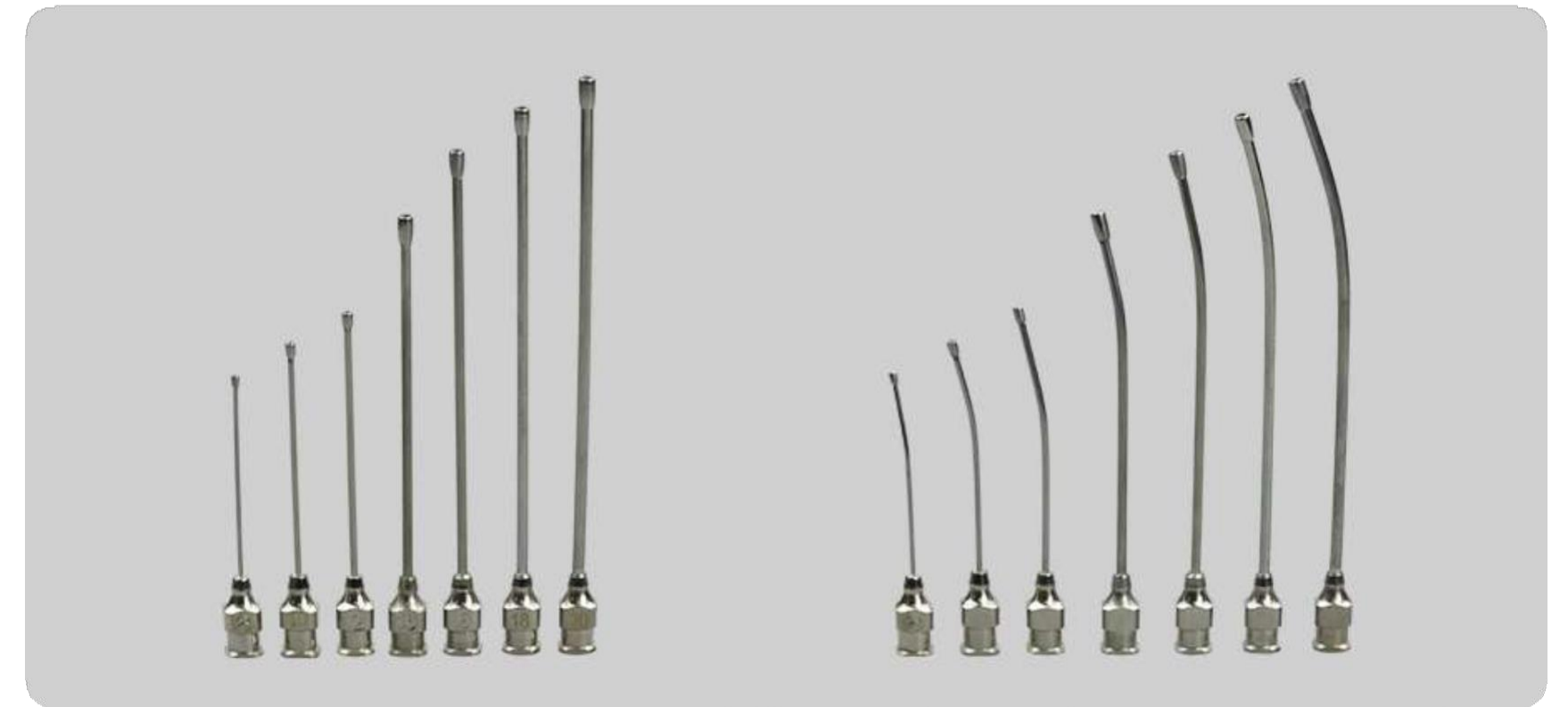

## Product information

Product Name: Rat Gastric Infusion Needle

Needle material: Copper nickel plating+stainless steel

Product customization: Customizable for sizes 8-20

Product feature: Dripping round needle tip to prevent scratches during animal feeding

## Rat gastric lavage needle

Model number	Needle tubing	Total length	Needle tube diameter	Needle diameter	Exposed length	Base interface
No.8	Straight/curved	45mm	0.8mm	1.3mm	32mm	Ruhr Mouth
No.10	Straight/curved	50mm	1mm	1.65mm	36.5mm	Ruhr Mouth
No.12	Straight/curved	55mm	1.67mm	1.18mm	42.5mm	Ruhr Mouth
No.16	Straight/curved	70mm	1.58mm	2.4mm	56.27mm	Ruhr Mouth
No.16	Straight/curved	80mm	1.59mm	2.37mm	66mm	Ruhr Mouth
No.18	Straight/curved	85mm	1.79mm	2.52mm	78.82mm	Ruhr Mouth
No.20	Straight/curved	90mm	1.98mm	2.6mm	78mm	Ruhr Mouth

Note: The above data may have slight errors due to manual measurement



# Metal internal thread solder needle

¼Inch ½Inch 1Inch 1.5Inch solder needle

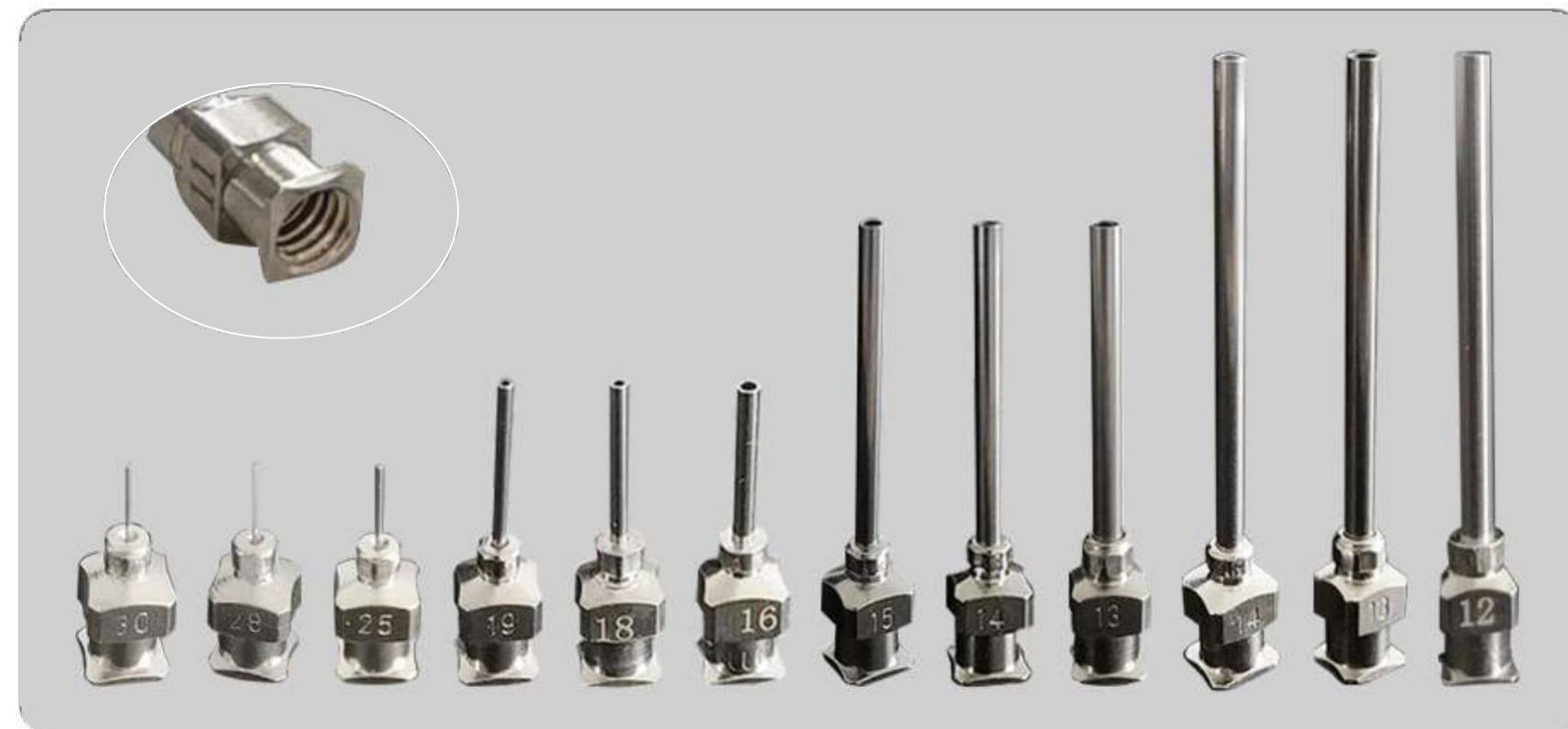

## Product information

Product Name: Metal Internal Thread Solder Needle  
 Needle material: Copper nickel plating+stainless steel+tin Base  
 length: 12mm  
 Base thread: Thread inner diameter 4.2mm (M5 internal thread)

## Metal internal thread solder needle

Model number	Inside diameter	Outside diameter	Wall thickness	Exposed length				Custom
				¼ Inch	½ Inch	1 Inch	1.5 Inches	
8G	3.5mm	4mm	0.25mm	6.5mm	13mm	25.4mm	38mm	support
10G	2.85mm	3.45mm	0.3mm	6.5mm	13mm	25.4mm	38mm	support
11G	2.45mm	2.95mm	0.25mm	6.5mm	13mm	25.4mm	38mm	support
12G	2.3mm	2.8mm	0.25mm	6.5mm	13mm	25.4mm	38mm	support
13G	1.9mm	2.4mm	0.25mm	6.5mm	13mm	25.4mm	38mm	support
14G	1.55mm	2.08mm	0.25mm	6.5mm	13mm	25.4mm	38mm	support
15G	1.3mm	1.78mm	0.25mm	6.5mm	13mm	25.4mm	38mm	support
16G	1.15mm	1.6mm	0.2mm	6.5mm	13mm	25.4mm	38mm	support
17G	1.05mm	1.5mm	0.2mm	6.5mm	13mm	25.4mm	38mm	support
18G	0.86mm	1.26mm	0.2mm	6.5mm	13mm	25.4mm	38mm	support
19G	0.72mm	1.02mm	0.15mm	6.5mm	13mm	25.4mm	38mm	support

Note: The above data may have slight errors due to manual measurement

Model number	Inside diameter	Outside diameter	Wall thickness	Exposed length				Custom
				¼ Inch	½ Inch	1Inch	1.5 Inches	
20G	0.6mm	0.9mm	0.15mm	6.5mm	13mm	25.4mm	38mm	支持
21G	0.5mm	0.8mm	0.15mm	6.5mm	13mm	25.4mm	38mm	支持
22G	0.4mm	0.7mm	0.15mm	6.5mm	13mm	25.4mm	38mm	支持
23G	0.3mm	0.6mm	0.15mm	6.5mm	13mm	25.4mm	38mm	支持
24G	0.27mm	0.55mm	0.15mm	6.5mm	13mm	25.4mm	38mm	支持
25G	0.25mm	0.5mm	0.125mm	6.5mm	13mm	25.4mm	38mm	支持
26G	0.22mm	0.45mm	0.125mm	6.5mm	13mm	25.4mm	38mm	支持
27G	0.2mm	0.4mm	0.125mm	6.5mm	13mm	25.4mm	38mm	支持
28G	0.17mm	0.32mm	0.075mm	6.5mm	13mm	25.4mm	38mm	支持
30G	0.15mm	0.3mm	0.075mm	6.5mm	13mm	25.4mm	38mm	支持
32G	0.1mm	0.24mm	0.08mm	6.5mm	13mm	25.4mm	38mm	支持
34G	0.06mm	0.23mm	0.08mm	6.5mm	13mm	25.4mm	38mm	支持

Note: The above data may have slight errors due to manual measurement

## Instructions for Metal Internal Thread Solder Needle

The internal thread needle belongs to the custom product, the thread is a certain vertical degree, not completely vertical, if it is used for soldering needle, the tin line is coated with oil, rosin and so on. It is recommended to buy a model with two rough sizes.

# Special base needle

Round base/square base/small base bell mouth



01: Large base round needle, flared large base needle, support thickness and length customized, the maximum thickness can be 10G.

02: Square base metal needle, this needle is a special needle, base interface is square, needle thickness and length support custom.

03: Small base flared needle, needle interface is copper nickel plated material, needle tube part is stainless steel material, support customized length and other thickness. This needle can be used with special high pressure valves.

## Special base needle

Serial Number	Available models	Total length	Exposed length	Base length	Inner diameter of base	Outer diameter of base
01	10G-32G	56mm	42mm	14mm	5.8mm	8mm
02	10G-32G	33mm	21mm	12mm	3.2mm	5.35mm
03	14G~19G	52.6mm	38.6mm	14mm	3mm	6mm

Note: The above data may have slight errors due to manual measurement

# Bi-directional stainless steel needle

5-25 pointed flat headed bidirectional needle

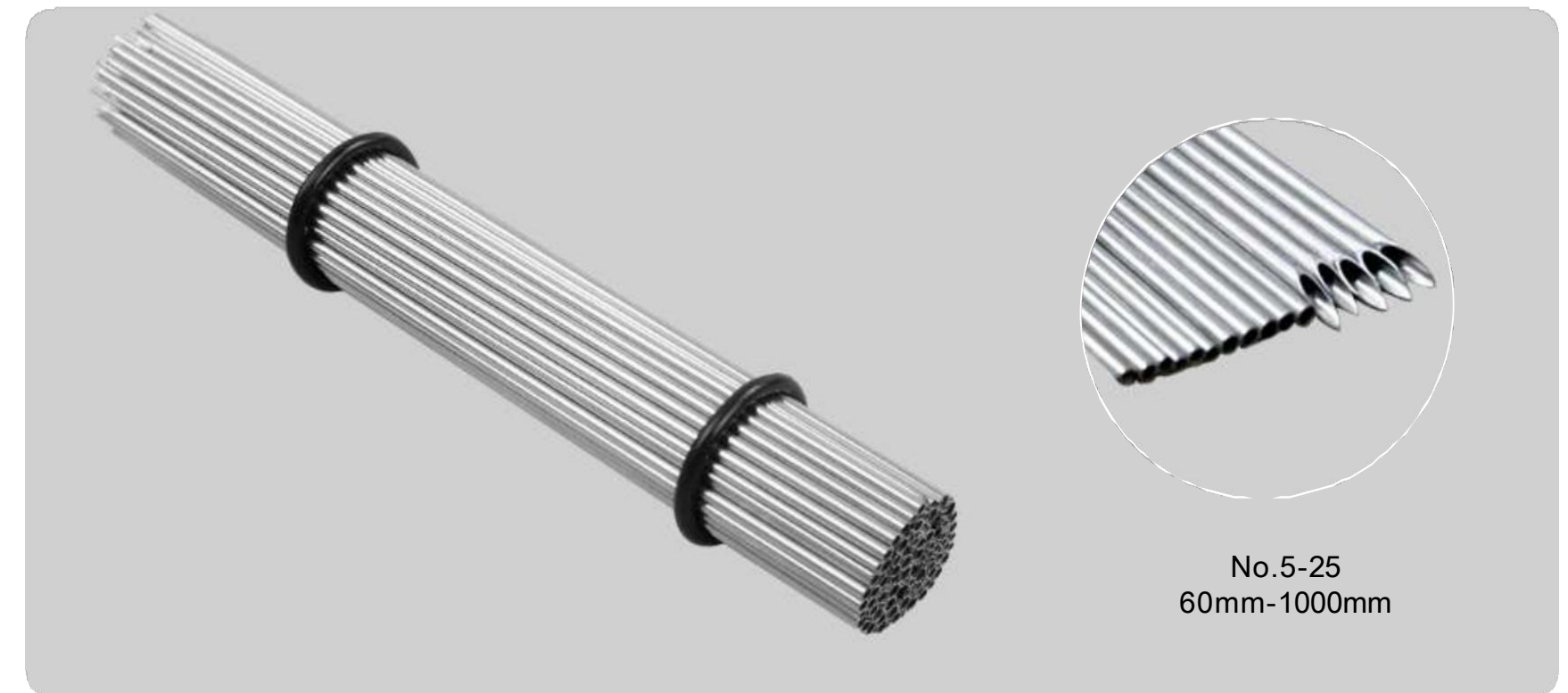

No.5-25  
60mm-1000mm

## Bi-directional stainless steel needle

Name	Available models	Both ends	Length	Product customization
Bi-directional stainless steel needle	No. 5-25	Sharp/flat	60~1000mm	Support non-standard customization

Note: Customized side hole/through side hole and other non-standard customization

# Tubular coaxial needle head

Dual interface/single interface concentric shaft needle



## Scope of application

1. Capillary.
2. Preparation of electrospinning intermediate control fiber.
3. Prepare hollow inorganic nanotubes and sensors.
4. Two-component core-shell structure fiber, drug slow release, sensor field.
5. Microfluidic.

## Common Matching Parameters for Tubular Coaxial Needles

Model number	Needle tube outer diameter (small)	Needle tube outer diameter (large)
18G/14G	1.26mm	2.08mm
19G/15G	1.02mm	1.78mm
22G/17G	0.7mm	1.5mm
25G/18G	0.5mm	1.26mm
30G/21G	0.3mm	0.8mm



Note: The above data may have slight errors due to manual measurement

## Reference for commonly used combinations and uses of electrospinning

1. Maximum 18G/14G suitable solution: micro-nanoparticle doping, high viscosity, strong volatility.
2. Large 19G/15G suitable solution: micro-nano particles doping, medium viscosity.
3. General medium 22G/17G suitable solution: nanoparticle doped, flowing volatile general solution.
4. Small 25G/18G suitable solution: nanoparticle doped, high flow volatile solution.
5. Minimum size 30G/21G applicable solution: undoped, ultra-high fluidity solution.

# Musashi metal needle

Musashi metal needle



## Musashi metal needle parameters

Serial Number	Model number	Total length	Inside diameter	Outside diameter	Exposed length	Inner diameter of base	Outer diameter of base
01	21G	18.6mm	0.5mm	0.8mm	3mm	4.16mm	6.65mm
02	22G	18.6mm	0.4mm	0.7mm	3mm	4.16mm	6.65mm
03	25G	18.6mm	0.25mm	0.5mm	3mm	4.16mm	6.65mm
04	28G	17.5mm	0.17mm	0.32mm	6.5mm	4mm	6mm
05	12G	57.6mm	2.3mm	2.8mm	42mm	4.16mm	6.65mm

Note: The above data may have slight errors due to manual measurement

## Musashi Metal Needle

The material at the interface of this needle base is copper nickel plating, and the fine tube part of the needle is stainless steel. The length of the base is slightly longer than that of the regular one, and the thickness and length of the needle support customization.

# Plastic flat needle for dispensing valve

Flare mouth flat needle

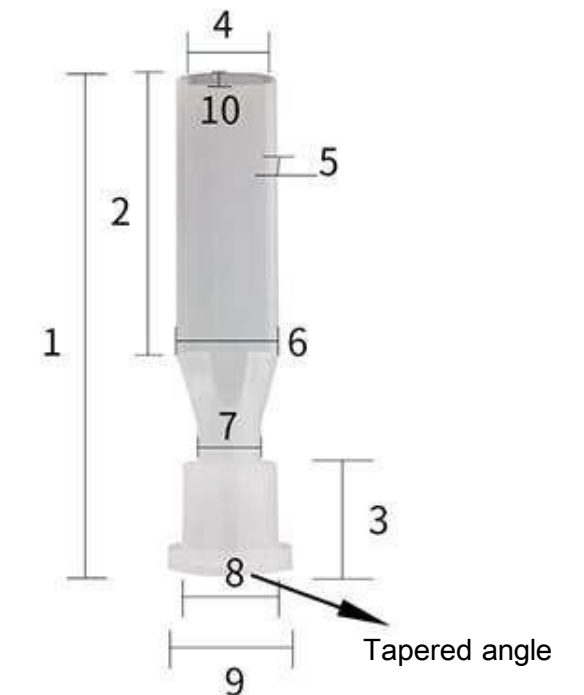

## Plastic flat needle for dispensing valve

1	2	3	4	4	6	7	8	9	10
67mm	39.7mm	13.6mm	12.4mm	4mm	14.3mm	8.6mm	10mm	16.3mm	2.5mm

Other models can also be customized

Note: The above data may have slight errors due to manual measurement

## Characteristics of Plastic Flat Needles for Dispensing Valves

The material at the interface of this needle base is copper nickel plating, and the fine tube part of the needle is stainless steel. The length of the base is slightly longer than that of the regular one, and the thickness and length of the needle support customization.

# Blunt needle

## Round head side hole blunt needle



### Round head side hole blunt needle parameters

Model number	Total length	Inside diameter	Outside diameter	Exposed length	Give	Individual packing
18G	68mm	0.86mm	1.26mm	50mm	Sharp needle	yes
18G	88mm	0.86mm	1.26mm	70mm	Sharp needle	yes
20G	88mm	0.6mm	0.9mm	70mm	Sharp needle	yes
21G	56mm	0.5mm	0.8mm	38mm	Sharp needle	yes
21G	68mm	0.5mm	0.8mm	50mm	Sharp needle	yes
21G	88mm	0.5mm	0.8mm	70mm	Sharp needle	yes
22G	56mm	0.4mm	0.7mm	38mm	Sharp needle	yes
22G	68mm	0.4mm	0.7mm	50mm	Sharp needle	yes
22G	88mm	0.4mm	0.7mm	70mm	Sharp needle	yes
23G	56mm	0.3mm	0.3mm	38mm	Sharp needle	yes
23G	68mm	0.3mm	0.3mm	50mm	Sharp needle	yes
23G	88mm	0.3mm	0.3mm	70mm	Sharp needle	yes
23G	118mm	0.3mm	0.3mm	100mm	Sharp needle	yes
25G	56mm	0.25mm	0.5mm	38mm	Sharp needle	yes
25G	68mm	0.25mm	0.5mm	50mm	Sharp needle	yes
27G	56mm	0.2mm	0.4mm	38mm	Sharp needle	yes
27G	68mm	0.2mm	0.4mm	50mm	Sharp needle	yes
30G	43mm	0.16mm	0.31mm	25mm	Sharp needle	yes

## Characteristics of blunt needles

### What is a blunt needle

The needle head of a blunt needle has no edge or edge, and the needle tube is flexible and elastic, making it difficult to directly puncture nerves or blood vessels, and can reach a relatively distant injection position; It is not possible to directly puncture the skin epidermis, and it needs to be opened through an open needle before use. The drug outlet is designed on the side of the needle tube.

### Advantages of blunt needles

1. The injection hierarchy control during operation is relatively simple.
2. The blunt needle has a round and blunt head, which can reduce the pain of needle puncture.
3. It can penetrate through skin tissue without directly injuring blood vessels and nerves, avoiding tissue damage, reducing bruising, bleeding, and swelling. The recovery speed of postoperative wounds is faster.
4. Compared to sharp needles, they are longer in length and can be used for fan-shaped and cross filling large areas such as the forehead. They have fewer pinholes and are easier to lay evenly.
5. Needles can be inserted in concealed areas to reach a distant injection location.

# Bidirectional injection chromatographic needle

## Bidirectional side hole needle

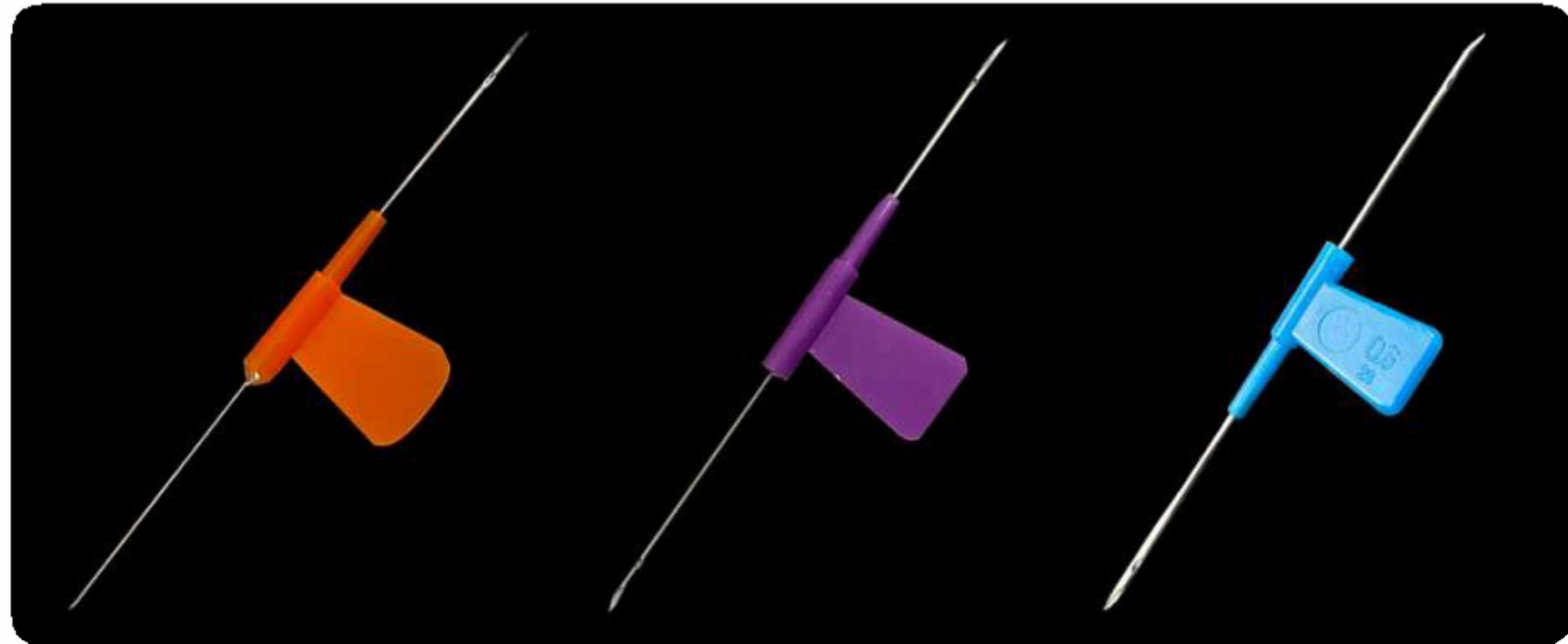

Bidirectional injection chromatographic needle parameters

Model number	Total length	Outside diameter	Inside diameter	Long needle length	Short needle length
NO.5	52mm	0.5mm	0.25mm	19.5mm	16mm
NO.5.5	51.6mm	0.55mm	0.27mm	19.5mm	14.4mm
NO.6	52.2mm	0.6mm	0.25mm	19.5mm	16mm

Note: The above data may have slight errors due to manual measurement

## Product characteristics

1

2

3

4

Chromatographic injection side hole two-way needle, headspace injection side hole two-way needle is a needle with special processing, the outlet is on the side of the needle, and the tip of the needle has two kinds of cone-sealed and unsealed, specially used for chromatographic gas injection and liquid injection, without blocking the needle, without damaging the headspace bottle injection port sealing pad, and without damaging the gas chromatograph injection port sealing pad. Prolong gasket life and improve analysis success rate